



General Regulations for the users of the Palexpo site

Version March 2023

The French version of these Regulations is the authentic text.

Table of contents

	Page
Administrative and legal regulations	1
Safety and security, fire prevention	16
Regulations for construction	25
General terms and conditions of sales and rental services.....	31
Telematics.....	35
Catering	40
Freight handling, Hire of lifting devices, Transport, Customs	42

CHANGES

[Cover page](#) – Version updated

[Page 44 – Article 5.1 Palexpo's Customs Office](#) – Address updated

Administrative and legal regulations

Index	Page
1. General provisions and right of refusal	2
2. Smoking ban	2
3. Minimum age.....	2
4. Animals	2
5. Waste	2
6. Photographs.....	2
7. Advertising and promotion	2
8. Advertising space rental.....	2
9. Music and royalties	2
10. Data protection	2
11. Intellectual property.....	3
12. Exhibited items, products and installations.....	3
13. Direct sales or cash-and-carry sales	4
14. Compulsory indication of retail prices	4
15. Labour law and working time	4
16. Withholding tax	5
17. Foreign staff employed at Palexpo.....	5
18. Temporary workers and recruitment (permanent and temporary employment agencies)	6
19. Users' liability for damage	6
20. Equipment rented by or made available to the User.....	6
21. Insurance	7
22. Financial obligations	7
23. Refund of value-added tax charged to buyers domiciled or headquartered abroad.....	7
24. Complaints.....	7
25. Clause nullity.....	7
26. Confidentiality.....	8
27. Settlement of disputes.....	8
Appendix 1 Summary of the main provisions applicable to the exhibition industry	9
Appendix 2 Table summarizing procedures required according to country of residence.....	10
Appendix 3 OCPM Form	11
Appendix 4 Cash Back VAT Reclaim AG Procedure.....	13
Appendix 5 AFC, Form to VAT refund.....	14
Appendix 6 Statement of Tax status (VAT)	15

Palexpo SA is the owner, manager and operator of the Geneva/Grand-Saconnex Exhibition and Congress Centre.

Organisers and exhibitors (hereinafter referred to as “the User(s)”) are responsible for ensuring that their activities conform to any legal requirements and for obtaining any authorisations required. The most important areas are mentioned below and, if necessary, Users should contact the competent authorities directly for information.

Palexpo SA shall not be held responsible in the event of infringement of legal provisions.

1. GENERAL PROVISIONS AND RIGHT OF REFUSAL

Palexpo SA enforces its rules and regulations in the areas and buildings used for fairs and exhibitions on the Palexpo site. Offenders risk exclusion from the exhibition without refund or compensation.

Palexpo SA relies on Users' support in maintaining discipline and good order during events. They are invited to notify Palexpo SA of any visitors whose behaviour seems to be detrimental to exhibitors or to the event as a whole, or of any non-exhibitors attempting to conduct business on the Palexpo site.

Palexpo SA reserves the right to refuse to host an event.

Palexpo SA requires that all events comply with all legal and regulatory provisions. In this context, Palexpo SA reserves the right to prohibit all or part of an event, at any stage, for any reason whatsoever, for example in relation to legal provisions, compliance with public policy or ethics, should this be relevant. Even in the event of a cancellation, the amounts due to Palexpo SA, for whatever reason, remain due.

2. SMOKING BAN

Smoking is strictly prohibited inside Palexpo premises.

All Users of the Palexpo site are asked to comply with the smoking ban inside Palexpo premises, and to ensure that others comply with it.

This ban also applies to any device with similar usage and effects to a cigarette – whether the similarity be due to the technical characteristics, the usage procedure or the substances involved – or that may produce smells that could bother third parties (e.g. e-cigarettes).

3. MINIMUM AGE

Children under 14 years must be accompanied by an authorised adult, except for exceptions. Palexpo SA reserves the right to control, in particular at the cash desks and the entries.

4. ANIMALS

Animals are not allowed inside Palexpo premises, except during special events dedicated to them.

The use or exhibition of live animals in shows or other events (whether public or private) is subject to authorisation from the Cantonal Veterinary Service.

For an application form, please contact:

Service de la consommation et des affaires vétérinaires (SCAV)

Quai Ernest-Ansermet 22

P.O. Box 76

CH - 1211 Geneva 4

Tel.: +41 (0)22 546 56 00

scav@etat.ge.ch

<https://www.ge.ch/organisation/service-consommation-affaires-veterinaires>

However, guide dogs and other assistance dogs are allowed.

5. WASTE

Users are responsible for disposing of waste from their stands during assembly, exhibition and dismantling.

Official Palexpo waste bags and containers for waste disposal can be ordered from the Exhibitor Relations Office.

The price of the waste bags includes collection and disposal of waste by Palexpo SA.

If a User does not evacuate his waste and can be identified by Palexpo SA, the latter will charge him for the evacuation of the waste.

6. PHOTOGRAPHS

Photographing, drawing or otherwise reproducing exhibited articles or an exhibitor's stand without the prior authorisation of the exhibitor is prohibited. As the organisers cannot accept any liability in this matter, it is up to individual exhibitors to enforce the ban on their own stands.

Nevertheless, exhibitors may not object to general views of the exhibition being taken with the permission of the organisers or of Palexpo SA, nor to the sale or publication of such views.

7. ADVERTISING AND PROMOTION

All sales promotion activities, surveys, distribution of publicity materials or any other form of publicity are only authorised at exhibitors' stand, providing the organiser has given prior authorisation.

Exhibitors are strictly prohibited from using audiovisual equipment in such a manner that the messages broadcasted or shown may be seen or heard on one or more neighbouring stands.

Any false or misleading advertising, of any nature whatsoever, is strictly prohibited and the perpetrator thereof may be expelled immediately from the event.

8. ADVERTISING SPACE RENTAL

For advertising space rental (paper or digital signage), please contact:

Neo Advertising SA

Rue Gourgas 5

CH-1205 Genève

Tel.: +41 (0)22 949 77 77

info@neoadvertising.ch / www.neoadvertising.ch

See also Article 3.3 of the section General terms and conditions of sales and rental of services.

9. MUSIC AND ROYALTIES

Royalties and related fees (in connection with the rights of performers and producers of sound carriers) for the use of background music (audio - video) and the organisation of minor musical events on the stands are paid by Palexpo SA. Users who play or perform music within these limits do not need to apply to SUISA for authorisation.

However, events such as concerts and musical shows of a significant size have to be announced to SUISA by the Users and special authorisation must be obtained for them.

SUISA

Cooperative Society of Music Authors and Publishers in Switzerland

Avenue du Grammont 11bis

CH-1007 Lausanne

Tel.: +41 (0)21 614 32 32

suisa@suisa.ch / <https://www.suisa.ch/en/customers.html>

10. DATA PROTECTION

10.1 It is expected that Users of the Palexpo location exchange data with Palexpo SA, which might include personal data of the User and third parties. Should any such data exchanges not be regulated by specific provisions, the contents of this Article 10 shall prevail.

10.2 By adhering to this Article, each User represents and warrants to Palexpo SA that he/she/it complies with all applicable data protection laws, in particular with regard to the protection of personal data (whether Swiss laws, provisions of the GDPR and/or any other law that would be applicable on a case-by-case basis). Palexpo SA hereby gives the same warranties to each of the Users.

10.3 With regard to the personal data of the User, the latter expressly accepts that the personal data that he/she/it personally transmits to Palexpo SA may be used for statistical purposes and for sending newsletters or other promotional mailings reasonably related to the context that prevailed when such personal data was transmitted to Palexpo SA.

10.4 In the event of a request sent to either the User or Palexpo SA by a person whose personal data would be included in the data referred to in this Article 10, and/or in the case of a relevant event in the field of data protection in relation to such data, the User or Palexpo SA, respectively, shall immediately inform the other party, and shall take, at their expense, the necessary actions to ensure compliance with applicable data protection laws and, in any case, reduce as much as possible the inconvenience and/or the damages that could concern Palexpo SA or the User, respectively.

10.5 Unless previously agreed in writing, the personal data included in the data referred to above may not be transmitted to third parties and/or used in a way that is not compliant with the purpose stated when collecting such data. Entities that (i) are part of the same group as Palexpo SA and/or (ii) process all or part of such personal data under a specific mandate of Palexpo SA shall not be considered as third parties within the meaning of this Article 10.5, it being specified that Palexpo SA takes the necessary measures to ensure that such data is treated confidentially and in accordance with the purpose also in this context.

10.6 Furthermore, the mandatory legal and statutory rights of the User and the data subjects referred to in this Article 10 are fully applicable.

10.7 Any processing of personal data in connection with a decision by the competent authorities (e.g. as part of the management of a pandemic risk) is reserved, in accordance with the framework thus applicable and its evolution. Palexpo SA will take the necessary steps to ensure that the User's rights in relation to his/her/its data are processed in accordance with the rules applicable in this context.

10.8 The data collected by Palexpo SA in connection with its infrastructure, in compliance with the applicable data protection rules, are the property of Palexpo SA.

11. INTELLECTUAL PROPERTY

As regards intellectual property, Palexpo SA shall not be liable under any circumstances in case of any dispute between exhibitors or between an exhibitor and a third party, and the injured party (whether an exhibitor or a third party) may not claim any action and/or compensation from Palexpo SA in its favour. Palexpo SA recommends arbitration using the services of the World Intellectual Property Organisation (WIPO) Arbitration and Mediation Centre, to which all event organisers may subscribe. The regulations applying in this regard (Rules for Palexpo trade fairs – Swift resolution of intellectual property disputes) may be found on <http://www.wipo.int/amc/en/center/specific-sectors/tradefairs/palexpo/>.

12. EXHIBITED ITEMS, PRODUCTS AND INSTALLATIONS

12.1 Medicinal products

In order to be offered for sale, a medicinal product must be registered by the Swiss authority for the control and authorisation of therapeutic products, Swissmedic, and be authorised by the Cantonal Pharmacist's Office:

Swissmedic

Swiss Agency for Therapeutic Products
Hallerstrasse 7
CH-3012 Berne

Tel.: +41 (0)58 462 02 11

Fax: +41 (0)58 462 02 12

<https://www.swissmedic.ch/swissmedic/en/home.html>

Service de la pharmacienne cantonale (SPhC)

Rue Adrien-Lachenal 8
1207 Genève

Tel.: +41 (0)22 546 51 88

pharmacienne.cantonale@etat.ge.ch

<https://www.ge.ch/organisation/service-pharmacienne-cantonale>

<https://www.ge.ch/fabriquer-importer-commercialiser-denrees-alimentaires>

You can find the current legislation governing therapeutic products on the website below:

<https://www.swissmedic.ch/swissmedic/en/home.html>

Except for a few rare exceptions, medicinal products may only be sold by pharmacies or drugstores.

Within the context of an exhibition, only medicines which are freely available for sale (those mentioned in Category E) can be sold, provided that they contain an active ingredient which is featured on List E (certain plants or essential oils, for example), they do not fall under Categories A - D and their use requires no specialist advice.

Additional information, as well as a copy of List E, can be obtained from the Cantonal Pharmacist's Office (SPhC).

12.2 Foodstuffs and consumer items (e.g. cosmetics)

In Switzerland, the Federal Office for Public Health (FOPH) is responsible for consumer protection and consequently for foodstuffs and other consumer items.

Federal Office of Public Health (FOPH)

Schwarzenburgstrasse 157
CH - 3003 Bern

Tel.: +41 (0)58 462 21 11

info@bag.admin.ch

<https://www.bag.admin.ch/bag/en/home/das-bag/kontakt-standort.html>

In Geneva, the competent authority for the control of foodstuffs and consumer items, as well as for veterinary issues is:

Service de la consommation et des affaires vétérinaires (SCAV)

Quai Ernest-Ansermet 22 - P.O. Box 76

CH - 1211 Geneva 4

Tel.: +41 (0)22 546 56 00

scav@etat.ge.ch

<https://www.ge.ch/organisation/service-consommation-affaires-veterinaires>

Switzerland, the legislation on foodstuffs and consumer items ensures that the health and safety of such articles can be controlled, and protects against fraud and deceit (in terms of the composition of foodstuffs, but also claims, labelling and advertising).

Foodstuffs and consumer items are regulated by the federal law of 20 June 2014 on foodstuffs and consumer items (LDAI) and its enforcement orders, namely the ordinance of 16 December 2016 on foodstuffs and consumer items (ODAI0Us).

Signage and labelling concerning products offered for sale must therefore be sufficient to allow appropriate use of the product, remain within the boundaries stipulated by the legislation and not be misleading.

Certain foodstuffs are subject to prior authorisation from the OFSP, and exhibitors are therefore requested to contact SCAV, which will be able to provide all the necessary information and advice.

IMPORTANT

According to the Ordinance on Foodstuffs and Consumer Items (ODAI0Us, SR 817.02) <https://www.admin.ch/opc/fr/classified-compilation/20143388/201705020000/817.02.pdf>, a responsible person with a professional address in Switzerland must be designated for each establishment in the food and consumer items sector.

The announcement form is available at the following address:

<https://www.ge.ch/organisation/service-consommation-affaires-veterinaires>

12.3 Alcohol and other products/services subject to special regulations

In application, as the case may be by analogy, of the Geneva law on catering, the serving of drinks, accommodation and entertainment (LRDBHD), it is forbidden to give (a) fermented drinks to adolescents under 16 years old, (b) distilled drinks to persons under 18 years old as well as (c) all alcoholic drinks to persons in a state of inebriation.

Furthermore, in accordance with the Federal Law on Alcohol, it is forbidden to advertise distilled beverages, in particular at events in which children and young people participate or which are essentially organised for them.

In any case, the User shall at all times comply with all special regulations that apply to the supply of products covered by such regulations or in connection with any regulated services.

12.4 Installations and technical equipment, hazardous products, gas bottles, heat-producing equipment and air compressors

For instructions governing the use of installations and technical equipment, hazardous products, gas cylinders and heat-producing equipment such as water-heaters, ovens and grills, please refer to the provisions contained in the section Safety and security/Fire prevention.

12.5 Infringements of various legal provisions

Any Users who do not comply with the legal provisions mentioned above concerning exhibited products, items and installations shall be held solely responsible for bearing any legal, civil or administrative consequences arising from their actions.

13. DIRECT SALES OR CASH-AND-CARRY SALES (Exhibition/sale, clearance sale, etc.)

The legal provisions set forth below must be observed by any merchant who rents space on his/her own behalf from Palexpo for the purpose of engaging in commercial activities designed to be open and accessible to the public (exhibition/sale, clearance sale, etc.).

13.1 Opening hours

(Pursuant to the provisions of the law of 15 November 1968 on shop opening hours and the law amending the law on shop opening hours of 30 April 2021)

The term "shop" refers to any facility or premises accessible to the public and used for the retail sale of any sort of goods. Accordingly, the exhibition halls and other premises of Palexpo that are accessible to the public and used for the retail sale of goods are considered to be shops.

The usual closing time for shops is 7.00 p.m. Closing times on Fridays and Saturdays are 7.30 p.m. and 6.00 p.m. respectively. Shops may remain open until 9.00 p.m. one day a week (Thursday).

All shops must be closed on Sundays and on all statutory holidays designated as such in Article 1 of the law of 3 November 1951 on public holidays.

Opening hours must be displayed on advertising materials and at the entrance to the premises.

When a commercial exhibition is of obvious cultural, artistic or documentary interest, or is obviously a combined event staged by one or more sectors of the national or cantonal economy, the Cantonal Retail Inspection Office (SCom) may, upon application submitted by the Users no later than 30 days prior to the event, grant an exemption to the provisions set forth by law for a maximum period of two weeks

Applications for such exemptions must be submitted directly to the SCom (see address below).

Exemptions remain subject to the collective labour agreements applicable to the retail trade sector, see:

<https://www.ge.ch/conventions-collectives-travail-cct>

13.2 Sales by private individuals, merchants or businesses

(Pursuant to the provisions of the federal law of 23 March 2001 on itinerant trade and the federal law of 17 June 2011 on measurements)

Any individual who, for the purpose of making a profit, sells goods to consumers within the boundaries of a hall or other leased premises must be in the possession of an Itinerant Merchant Permit issued by the respective cantonal authority. This obligation also applies to sales staff.

No Itinerant Merchant Permit is required for merchants or businesses taking part in events deemed by the authority to be of obvious commercial interest or benefit to tourism, or for merchants or businesses who offer goods or services, or take orders for such goods or services, within the premises defined by the organiser as authorised by the respective authority (exhibition or trade fair).

The inspection (official verification and stamp) of measuring instruments used or useable in retail trade as well as the inspection of measurements designating quantities falls under the jurisdiction of the Test and Measurement Department of the SCom

13.3 Activities and products/services subject to authorisation

Palexpo SA specifically draws the User's attention to the legal provisions concerning the free delivery and takeaway of alcoholic beverages, tobacco products and tobacco-like products (LTGVEAT) as well as to the federal and cantonal regulations applicable to certain activities and products.

The User shall take the necessary steps to obtain all relevant authorisations and shall ensure that the conditions are respected.

14. COMPULSORY INDICATION OF RETAIL PRICES

(in compliance with the provisions of the Federal Ordinance on the display of retail prices, 11 December 1978)

The retail price of all goods on display for sale to customers must be indicated.

The net sales price must be indicated clearly and legibly in Swiss Francs.

This provision extends not only to exhibitors but also includes sales points dealing in tobacco, newspapers, books, postcards, postage stamps, sweets, etc. as well as catering establishments serving drinks or food.

Goods designed mainly for further development, conversion or sale to third parties in the practice of their trade, are not subject to this provision.

Exhibitors who fail to comply with this provision must answer to the authority mentioned below.

Please direct any application for exemption or request for further information to:

Service de police du commerce et de lutte contre le travail au noir (PCTN)

Bandol Centre
Rue de Bandol 1
CH-1213 Onex

Tel.: +41 (0)22 388 39 39

pctn@etat.ge.ch

<https://www.ge.ch/organisation/ocirt-service-police-du-commerce-lutte-contre-travail-au-noir-pctn>

15. LABOUR LAW AND WORKING TIME

Users must comply – and ensure, through contracts, that their entire subcontracting chain complies – with all provisions on the social protection of workers and working and salary conditions applicable to the relevant activity sector in Geneva. Users must be able to prove at any time, upon the request of the competent bodies or authorities or Palexpo SA, that they and their entire subcontracting chain are up-to-date with these provisions.

Users hereby give their prior consent to Palexpo SA obtaining any information about them on behalf of the competent authorities, particularly the Cantonal Labour Relations and Inspection Office (OCIRT), the Commission de l'inspection paritaire des entreprises (IPE) and any competent joint committee. Users shall require, by contract, that their subcontractors also give consent for Palexpo to take such actions in their regard and that they require the same of their own subcontractors.

15.1 Legislation

(see Appendix 1)

Staff working at Palexpo are subject to the provisions of the following:

- The federal law of 13 March 1964 on labour (LTr);
- Ordinance 1 of 10 May 2000 on the law on labour (OLT1);
- The federal law of 20 March 1981 on accident insurance (LAA);
- The ordinance of 19 December 1983 on prevention of insurance (OPA);
- The extended collective labour agreements;
- Standard employment contracts with mandatory minimum salaries;
- The law on inspection and labour relations of 12 March 2004 (LIRT);
- The foreign nationals and integration act of 16 December 2005, FNIA;
- The ordinance on the admission, residence and the exercise of a gainful activity of 24 October 2007;
- The law on seconded employees of 8 October 1999 (LDét).

See also the section Safety and security/Fire prevention, article on Prevention of accidents at work.

For more information, Users may contact:

Office cantonal de l'inspection et des relations du travail (OCIRT)

Rue David-Dufour 5

P.O. Box 64

1211 Geneva 8

Tel.: +41 (0)22 388 29 29

Fax: +41 (0)22 546 97 25

gtDET@etat.ge.ch

<https://www.ge.ch/organisation/ocirt-service-inspection-du-travail-it>

Federal legislation may be consulted on:

<https://www.admin.ch/opc/fr/classified-compilation/82.html>

15.2 Working time

(see Appendix 1)

Staff deployed to assemble, maintain or dismantle stands or serve visitors during events do not need authorisation to work at night or on Sundays, if required.

These special provisions do not cover activities not directly linked to events, to which the stipulations on work and rest times set out in the Federal Employment Law remain applicable.

The legal provisions are summarised on the site:

<https://www.ge.ch/travailler-dimanche-nuit-jour-ferie>

16. WITHHOLDING TAX

Taxpayers in the categories listed below are subject to a tax deduction at source:

1. Foreign workers who do not hold a C permit i.e. those with an A, B or L permit, asylum seekers, and so on;
2. Cross-border workers of Swiss or foreign nationality;
3. Seasonal workers;
4. Foreigners who hold a limited-stay permit that allows them to be gainfully employed in Switzerland without taking up residence (90 or 120 day permit);
5. Young persons who are still minors on 1 January of the current year, or when they arrive in the Canton if after 1 January, irrespective of their nationality or permit type;
6. Professional entertainers, musicians, soloists, members of orchestras, actors, lecturers, sportsmen, and others, including people domiciled in foreign countries who belong to troupes giving a few performances at an event.

Further details may be obtained from:

Administration fiscale cantonale

Service de l'impôt à la source

Hôtel des finances

Rue du Stand 26

P.O. Box 3937

CH-1211 Geneva 3

Tel.: +41 (0)22 327 70 00

<https://www.ge.ch/impot-source>

17. FOREIGN STAFF EMPLOYED AT PALEXPO

Secondment of staff and independent service providers to Palexpo (see Appendices 2 and 3)

These instructions do not cover the general conditions of residence or longer-term secondments (more than 90 days), which are subject to other regulations. They constitute a non-exhaustive summary of instructions for the situations most frequently encountered by Users.

The terms of access to the Swiss employment market vary depending upon whether the worker concerned is a national:

- Of a member state of the European Union before its enlargement (EU-27): Austria, Belgium, Bulgaria, Croatia, Cyprus, Czech Republic, Denmark, Estonia, Finland, France, Germany, Greece, Hungary, Ireland, Italy, Latvia, Lithuania, Luxembourg, Malta, the Netherlands, Poland, Slovakia, Slovenia, Portugal, Romania, Spain and Sweden (note that the United Kingdom is no longer part of the EU as of 1 January 2021);
- Of a state within the European Free Trade Association (EFTA): Iceland, Liechtenstein, and Norway;
- Of another country.

See Summary Overview - Appendix 2

Two different procedures must be observed respectively:

- Notification for which the OCIRT is the authority responsible (online registration); or
- Application for short-term residence and work permits, for which the Canton Immigration Authority (OCPM) is the authority responsible - see Appendix 3.

17.1. EU-27 or EFTA nationals

17.1.1 Normal procedure: notification is only required if employment exceeds eight days

Registration is only obligatory if employment exceeds eight days in the same calendar year.

In such cases, independent service providers and employees seconded by companies based in other countries must contact the OCIRT at least eight days before the planned start of work at Palexpo (see Article 17.4, Registration procedure).

17.1.2 Special cases: notification is required from the first day

Some specific sectors, like the construction are regarded as special cases. For Users, the activities concerned are:

- Cleaning;
- Catering;
- Itinerant trade;
- Landscaping;
- Mechatronics;
- Security and surveillance;
- Stand assembly and industrial cleaning;
- Steel and construction workers;
- Structural workers;
- Sub-trade activities.

For these activities, notification is required from the first day, irrespective of the length of employment or secondment (see Article 17.4, Notification procedure).

17.1.3 Special cases: United Kingdom nationals

Following the withdrawal of the United Kingdom from the European Union on 31 December 2020, the free movement of persons ceases to apply. As a result, United Kingdom nationals are considered third-country nationals. On 4 December 2020, Switzerland signed an agreement with the United Kingdom which allows the registration procedure to continue for cross-border service providers whose stay does not exceed 90 days per calendar year. The agreement is currently limited to two years.

17.2 Nationals of non-EU/non-EFTA countries

17.2.1 Normal procedure: a permit is only required if employment exceeds eight days

A permit need only be applied for if employment exceeds eight days in the same calendar year. In such cases, independent service providers and employees seconded by companies based in non-EU/non-EFTA countries must contact the OCPM at least eight days before the work planned at Palexpo commences (see Article 17.4, Permit procedure).

17.2.2 Special cases: a permit is required from the first day

For the sectors listed in Article 17.1.2, nationals of these countries also require a permit from the first day, irrespective of the length of employment or secondment (see Article 17.5, Permit procedures). Access to the employment market in these sectors (except for the seconded employees) is subject to priority for national workers. However, the common local working conditions, and salary must be respected at all times.

Palexpo SA is happy to provide Users with lists of local companies which are able to carry out such work.

17.3 Notification procedure

Notification must take place online at least 8 days before work starts at the following address:

https://www.sem.admin.ch/sem/en/home/themen/fza_schweiz-eu-efta/meldevfahren.html

Independent service providers are legally bound to present the following documents during an inspection designed to verify that they are indeed acting independently at the place where their service is being rendered (applicable since 1 January 2013).

- A copy of the proof of notification;
- The social security certificate (form A1) (proof of the Legal Regulations applicable to social security);
- A copy of the mandate concluded with the customer or principal: https://www.sem.admin.ch/dam/data/sem/eu/fza/meldeverfahren/form2_selbstaendige-f.pdf;

These documents must be submitted in one of the official languages (French, German, Italian). Exceptionally they can be accepted in English.

The legal duty to register workers is the employer's responsibility.

One single notification suffices to announce several secondment periods for the same mandate.

Important: Seconded employees and independent service providers must bring along a copy of the OCIRT certificate.

17.4 Permit procedure

Permit applications must be submitted to the OCPM at the following address:

Office cantonal de la population et des migrations (OCPM)

Service étrangers
Route de Chancy 88
P.O. Box 2652
1211 Geneva 2

Tel.: +41 (0)22 546 47 95

ocpm@etat.ge.ch

<https://www.ge.ch/organisation/office-cantonal-population-migrations-ocpm>

Permit applications must be submitted:

- a. On the relevant OCPM form (see Appendix 3); or
- b. On paper bearing the letterhead of the company making the application, with the proviso that all the information requested in the OCPM form is provided (particularly the name and dates of the exhibition and the stand number), duly dated, stamped and signed; or
- c. On the individual permit application form, which may be downloaded from: <https://www.ge.ch/document/ocpm-formulaire-td-travailleurs-detaches-ue/aele/extra-europeens>

Anyone holding a valid residence card for a European Community country is asked to include a copy thereof.

Incomplete applications or those on plain paper (without letterhead) will be rejected.

The OCPM will indicate that the application has been approved by stamping the documents and returning them to the sender by fax.

17.5 Subsequent changes to a registration or permit

The authority responsible (OCIRT or OCPM) must be informed immediately if circumstances change subsequent to registration or the receipt of a permit (e.g. change in the time required for the work, additional staff or representation by a different person).

17.6 Remuneration

It is mandatory to respect common local working conditions and salary. For more information on remuneration of seconded staff, see:

<https://www.ge.ch/organisation/ocirt-direction-generale-office-cantonal-inspection-relations-du-travail-for-the-regulated-professions>, and <https://www.ge.ch/calculateur-salaire-ligne> for all other professions.

If work is performed by subcontractors domiciled or headquartered in Switzerland or abroad, the contracting company, as the sole, general or main contractor, must require, by contract, that its subcontractors comply with the provisions above. It may be held liable for non-compliance with these rules. In the construction sector, it must also ensure that the subcontractors observe the working conditions and the minimum wage in Geneva.

Employers must respect the mandatory minimum wages set out in collective labour agreements (CLAs) or standard employment contracts (STCs) for their industry.

17.6.1 Collective labour agreements

For catering, construction, security and cleaning staff, in particular, the collective labour agreements in force in the Canton of Geneva and Switzerland must be respected.

Please refer to <https://www.ge.ch/respecter-conventions-collectives-travail-cct/cct-entreprises-applicables-geneve>.

17.6.2 Model employment contract

For personnel involved in setting up and dismantling exhibition stands, transporting goods on behalf of third parties, including the retail trade, please refer to <https://www.ge.ch/respecter-contrats-type-travail-ctt/ctt-vigueur-geneve>.

17.6.3 Geneva minimum salary

In the absence of an applicable mandatory salary, any company that obtains a contract in Geneva and whose workers are usually employed in Geneva must demonstrate that it respects the Geneva minimum salary.

Each year, the minimum salary is indexed to the consumer price index for the month of August, based on the index in force on 1 January 2018. The minimum salary is only indexed if the consumer price index increases.

For the application of the minimum salary provisions, please refer to <https://www.ge.ch/appliquer-salaire-minimum-genevois>.

18. TEMPORARY WORKERS AND RECRUITMENT (permanent and temporary employment agencies)

Permanent and temporary employment agencies are not allowed to conduct their business unless they are in possession of a permit from the relevant authorities. If they do not have a permit, they risk criminal prosecution.

Clients of such companies also expose themselves to the risk of criminal prosecution if they knowingly use companies which they know not to be in possession of the required permit.

Users shall therefore ensure that they use only agencies or service providers duly authorised to conduct business.

Private employment or recruitment agencies based abroad are not permitted to provide staff in Switzerland. The use of an employment agency based in Switzerland is obligatory.

It is the responsibility of temporary employment agencies which provide staff for trade-fair stands (e.g. hostesses, models) to directly contact the OCPM for applications for permits or registrations (for European Union nationals) or the OCIRT for applications (for other workers).

19. USERS' LIABILITY FOR DAMAGE

Users are liable for any damage caused to the walls, floors, pillars and installations of the Palexpo site, whether the damage was caused by themselves or by third parties contracted by them.

As such, users must take out insurance (see hereafter Article 21, Insurance).

20. EQUIPMENT RENTED BY OR MADE AVAILABLE TO THE USER

The equipment rented by the User or made available to the User is placed under the User's sole responsibility. The User undertakes to take out insurance covering the equipment loaned or made available to the User against, in particular, theft, fire, water damage and damage of any kind. In addition, the User must have civil liability insurance covering any physical or material damage that may occur as a result of the use of the equipment loaned or made available. Premiums are to be paid by the User.

When a permit or authorisation is required to take possession of and/or use the equipment rented or made available, it is the sole responsibility of the User to ensure that the User has all the permits and authorisations that may be required for its proper use.

The User undertakes to take appropriate measures to ensure that no unauthorised person takes possession of or uses all or part of the rented or made available equipment.

By accepting the rented or made available equipment, the User declares that the User and any authorised person who takes possession of and/or uses all or part of this equipment has the necessary physical and mental aptitudes and sufficient experience to ensure that the equipment can be possessed and/or used in a manner that is safe for the User, all third parties, the infrastructure and the environment.

The equipment is handed over to the User in good working order and must be returned in the same condition. It must not be modified by the User under any circumstances. Any damage to or disappearance of the equipment rented or made available will result in the User being invoiced for repairs, as appropriate for replacement value.

21. INSURANCE

21.1 Civil liability insurance

21.1.1 Damage to third parties and to premises, installations and equipment on the Palexpo site

All damage caused to third parties and to the premises, installations and equipment belonging to Palexpo SA shall be at the expense of Users and their subcontractors.

In order to ensure coverage against claims for damages resulting from the risks mentioned above, Users or their subcontractors must take out civil liability insurance. Upon request from Palexpo SA, Users must provide a copy of their insurance certificates. The minimum sum guaranteed per claim must be sufficient to cover the risk inherent in the exhibition. In the absence of adequate insurance cover, Palexpo SA reserves the right to refuse to make the premises available.

In the event that the responsibility for the damages incurred lies with a third party (exhibitor, exhibitor's or organiser's subcontractors, visitors to the event) and there is found to be no or inadequate insurance cover, it becomes the organiser's responsibility to bear the cost of claims for damages resulting from the risks mentioned above.

21.2 Fire, exhibition and transit insurance

Users and their subcontractors, must insure all installations and equipment belonging to them or which they have rented against the risk of "fire" during the event.

"Fully comprehensive insurance cover for the period of the exhibition" and "fully comprehensive insurance for transit" are optional.

Palexpo SA shall not be held liable in the event of loss or damage to goods belonging to Users or third parties which are placed on the premises of Palexpo, whether locked or not. Users and third parties leave goods on the premises at their own risk.

Users may take out private insurance policies through the insurance policies concluded between Palexpo SA and Swiss insurers.

22. FINANCIAL OBLIGATIONS

Exhibitors must pay the fee for floor-space rental in full by the date set by the organiser in the general regulations for the relevant exhibition.

Invoices for technical and other services are payable net upon receipt. Palexpo SA reserves the right not to deliver orders if payment is not received.

Exhibitors are responsible for the payment of all expenses incurred in connection with the installation of their stand, whether it is installed by themselves, by the organisers or by third parties (see hereafter Article 24, Complaints).

23. VALUE-ADDED TAX (VAT)

23.1 Swiss VAT liability of foreign companies

For information on this subject, see :
<https://www.estv.admin.ch/estv/en/home/value-added-tax/vat-tax-liability/foreign-companies.html>

23.2 Refund of VAT charged to buyers domiciled or headquartered abroad

VAT paid in connection with participation in an exhibition, such as floor-space rental, technical services, assembly of the exhibition stand, meals,

reception expenses and hotel accommodation is refundable in full by the tax authorities.

VAT rates are:

- 7.7% VAT is the standard rate for most goods and services;
- 3.7% VAT is the standard rate for hotels (including breakfast);
- 2.5% VAT is the standard rate for books, newspapers and food.

VAT paid in Switzerland in connection with trade show participation is refundable under the following conditions:

- Claimants must:
 - be domiciled and headquartered abroad;
 - prove that they conduct a registered business; and
 - not generate turnover in Switzerland – i.e. they may not supply goods or provide services in the country;
- The purchased goods and services must contribute to the generation of a type of business income that would be subject to Swiss VAT if generated in Switzerland;
- Applications for refunds must be filed within six months of the end of the calendar year in which the purchase was made (i.e. they must reach the authorities by 30 June of the following year);
- The refundable VAT for the year must amount to at least CHF 500;
- Applicants must appoint a representative who is domiciled or headquartered in Switzerland;
- The country in which applicants are domiciled or headquartered must grant reciprocal rights. At present, this applies to the following countries:
Australia, Austria, Bahrain, Belgium, Bermuda, Bulgaria, Canada, Croatia, Cyprus, Czech Republic, Denmark, Estonia, Finland, France, Germany, Greece, Hong Kong, Hungary, Ireland, Israel, Italy, Japan, Latvia, Lithuania, Luxembourg, Macedonia, Malta, Monaco, the Netherlands, Norway, Poland, Portugal, Romania, Saudi Arabia, Serbia, Slovakia, Slovenia, Spain, Sweden, Taiwan, Turkey, United Arab Emirates, United Kingdom, and the United States of America.

As a Swiss tax representative is required by law, we recommend that you file your refund application through a specialist company.

We can recommend the following company:

Cash Back VAT Reclaim AG

Gewerbestrasse 11
CH-6330 Cham

Tél.: +41 (0)41 747 30 00

info@cashback.ch / www.cashback.ch

The commission is 15% on the refunded VAT. There is no basic fee and no charge for instructions to clients.

To ensure that your VAT refund goes smoothly, please send the following documents to Cash Back VAT Reclaim AG by the end of May:

- original invoices (the name and address of the foreign company must be mentioned on the invoice); and
- your contact details (address, bank details, a contact person in case of inquiries).

Cash Back VAT Reclaim AG would be happy to answer any questions you may have and will send you the necessary documents if you wish.

See Appendices 4 to 6.

24. COMPLAINTS

Complaints relating to services provided (technical, equipment, etc.) must be addressed to Palexpo SA before or during the event. No complaints of this nature can be taken into consideration after the conclusion of an event.

Any complaints regarding invoicing must be made no more than 30 days after the date of the invoice (see Article 20, Financial obligations, and Article 26, Settlement of disputes).

25. CLAUSE NULLITY

If any of these Administrative and Legal Regulations should become ineffective, invalid or contrary to an overriding rule of law, the other provisions shall remain unchanged and the Administrative and Legal Regulations shall not become null and void. The aforementioned provisions shall be interpreted or replaced with the closest possible equivalent.

26. CONFIDENTIALITY

The exhibitors undertake not to divulge, display or make available to third parties the conditions of their participation in an exhibition (rental, financial, technical or other conditions) without prior written authorisation from the organiser and Palexpo SA.

This confidentiality clause continues to apply beyond the conclusion of the event.

27. SETTLEMENT OF DISPUTES

Any disputes shall be subject to Swiss law.

The parties concerned shall attempt to reach an amicable settlement in the event of any disputes, disagreements or claims resulting from these regulations or referring to the same, including the existence, validity, nullity, interpretation, execution or non-execution of any possible violations of the current regulations.

If a dispute cannot be settled out of court, the parties acknowledge that the courts of the Republic and Canton of Geneva have exclusive jurisdiction, an appeal to the Supreme Court notwithstanding.

This does not apply to the case of an intellectual property dispute between Users and between a User and a third party during the event in question. In such cases, the sole rules applying shall be the Rules for Palexpo trade fairs – Swift resolution of intellectual property disputes (see Article 11) if the organiser has chosen to apply them to the event.

Enclosures:

- | | |
|------------|---|
| Appendix 1 | Summary of the main provisions applicable to the exhibition industry |
| Appendix 2 | Table summarizing procedures required according to country of residence |
| Appendix 3 | OCPM Form |
| Appendix 4 | Cash Back VAT Reclaim AG Procedure |
| Appendix 5 | AFC, Form to VAT refund |
| Appendix 6 | Statement of Tax status (VAT) |

SWISS FEDERAL EMPLOYMENT LAW – WORK AND REST TIMES

Summary of the main provisions applicable to the exhibition industry

(subject to special exceptions for restaurant and security businesses)

Also subject to for employees more favourable conventional contractual or collective provisions or provisions for professional applications

Working time

Employees may work for up to **11 consecutive days** insofar as they have at least 3 work-free days and daily rest time (83 consecutive hours of rest time) and the five-day week is on average maintained over the calendar year.

Subject to the provisions below, employees may not exceed 50 hours of actual work during the period from Monday to Sunday.

In emergencies or in cases of extraordinary additional work, a **maximum** additional working time of **two hours per employee and day** may be demanded against payment of a supplement of 25% (unless these working hours are compensated by equivalent leave, with the agreement of the employee). Additional working time, however, may not exceed 140 hours in a calendar year.

Wages

The wages paid to the employee must be based on the wages customarily awarded in Geneva for the same activity.

Daily minimum rest times

The daily rest time has been defined as a minimum of **11 consecutive hours** for adult employees, which may, however, be reduced to eight hours once a week insofar as the daily minimum rest time averages 11 hours over a period of two weeks.

Breaks

The work must be interrupted by breaks of at least 15 minutes during a working day in excess of 5.5 hours, of at least 30 minutes during a working day in excess of seven hours and of at least one hour during a working day in excess of nine hours. An uninterrupted working time exceeding 5.5 hours entitles to an additional break of 15 minutes.

Note: Breaks count as working time if the employee is not allowed to leave his workplace.

Day and evening work

Work during the day is regarded as work between 6.00 am and 8.00 pm, evening work is regarded as work between 8.00 and 11.00 pm

Each employee may only work for 12 ½ periods, 14 hours apart, including any breaks and additional work. The periods for day and evening work may in agreement with the employees be moved by one hour (5.00 am to 10.00 pm or 7.00 pm to midnight). The selected periods apply to all employees.

Night work (between 11.00 pm and 6.00 am, without this period being moved, see above)

Night work may be considered without the procurement of a permit against the payment of a wage supplement of at least 25%.

Night work may (within 24 hours) last for a maximum of nine or ten hours (under specific conditions, see art. 29 OLT 1) with breaks. Daily minimum rest periods, however, must still be observed. The provisions for night work, with the exception of the wage supplement, apply when part of the employee's working time falls within the legally stipulated times for night work.

Work on Sundays and public holidays

Work on Sundays and public holidays is also possible without the procurement of a permit in the event of urgent, properly demonstrated requirements or in the event of technical or economic necessity against the payment of a wage supplement of at least 50%.

Each employee must have at least 26 work-free Sundays in each calendar year, which may be distributed irregularly throughout the year insofar as at least one free Sunday is guaranteed per quarter.

A corresponding equivalent rest period must be granted in the week before or after the work on Sunday or the public holiday. This rest time period must include the daily rest time, i.e. it must be of at least 35 hours duration. The compensation rest time may be awarded en bloc for a calendar year.

Employee consent

The employees' consent is required for night work and work on Sundays.

Younger employees (below the age of 18), pregnant women or breast-feeding mothers

Special working conditions apply to employees in these categories. In such cases, we therefore request you to consult our offices where you will be provided with comprehensive information.

List of employees and duty of disclosure

When requested to do so, the employer will be obliged to provide comprehensive information or to provide the required documents to the authorities monitoring the law. The employer must keep a list of employees (with details about their identity, their working and their compensation rest periods).

Ordinance 2 of the federal law on labour (OLT2); Exemption for night's and Sunday's work

The employer is permitted to employ workers at night, on Sundays and in a continuous fashion when this relates to business conference and convention companies employing workers in the provision of services and assistance to visitors, or being engaged in maintenance activities.

This also applies to Exhibition centres when employing workers in the assembly and dismantling process, in the provision of services to exhibition stands and working on entrance desks as well as engaging in maintenance activities.

The employment inspectorate (OCIRT) is at your disposal for further information.
P.O. Box 64, CH-1211 Geneva 8 - Tel. +41 (0)22 388 29 29 - E-mail: gtDET@etat.ge.ch

**TABLE SUMMARIZING THE PROCEDURES REQUIRED ACCORDING TO COUNTRY OF RESIDENCE
SHORT-TERM SECONDMENT (less than 90 days)**

Company based in / Independent Service Provider national of

UE – 27 / EFTA	Other countries
<p>Austria, Belgium, Bulgaria, Croatia, Cyprus, Czech Republic, Denmark, Estonia, Finland, France, Germany, Great Britain (agreement on the mobility of service providers valid for 2 years), Greece, Hungary, Ireland, Italy, Latvia, Lithuania, Luxembourg, Malta, the Netherlands, Poland, Portugal, Romania, Slovakia, Slovenia, Spain, Sweden (EU-27)</p> <p>(No transitional provisions apply to them anymore). Iceland, Liechtenstein, Norway (EFTA)</p>	<p>All other countries of the international community.</p>

1 to 8 days of activity (within one calendar year)

Normal procedure	Special cases: Construction, cleaning, security, catering	Normal procedure	Special cases :	Normal procedure	Special cases:
No requirements Except for special cases	Online notification from the 1st day	No requirements Except for special cases	<p>a) Construction, cleaning, security</p> <p>b) Catering</p>	No requirements Except for special cases	<p>Construction, cleaning, security, catering</p>
No requirements Except for special cases	Online notification from the 1st day	No requirements Except for special cases	<p>a) Permit from OCPM from the 1st day OCPM form</p> <p>b) Online notification from the 1st day</p>	No requirements Except for special cases	<p>Permit from OCPM from the 1st day OCPM form</p>

9 to 90 days of activity (within one calendar year)

Normal procedure	Special cases	Normal procedure	Special cases	Normal procedure	Special cases
Online notification	Online notification	Online notification	<p>Construction, cleaning, security, parks & gardens</p>	Permit from OCPM OCPM form	<p>Construction, cleaning, security, parks & gardens</p>
Online notification	Online notification	Online notification	<p>Permit from OCPM OCPM form</p>	Permit from OCPM OCPM form	<p>Permit from OCPM OCPM form</p>

Application for residence and short-time work permit for nationals from countries other than the EU/EFTA members

Company: *If more than 8 applications, please duplicate this form!*

Address: *Please return to:*

City: Office Cantonal de la Population et des Migrations
Service Etrangers
Route de Chancy 88
P.O. Box 2652
CH-1211 Geneva 2

Country: ocpm@etat.ge.ch
Fax: +41 (0)22 546 48 22

E-mail:

We hereby apply for a residence and short-time work permit for our employees listed below for the following exhibition at PALEXPO:

Exhibition:	From:	To:	Stand N°:
-------------------	-------------	-----------	-----------------

Name of employee(e)			
First name			
Date of birth			
Address abroad			
Nationality			
Function on stand			
Duration of activity at PALEXPO from			to

Name of employee(e)			
First name			
Date of birth			
Address abroad			
Nationality			
Function on stand			
Duration of activity at PALEXPO from			to

Name of employee(e)			
First name			
Date of birth			
Address abroad			
Nationality			
Function on stand			
Duration of activity at PALEXPO from			to

Place and date:	Stamp and authorized signature:
-----------------------	---------------------------------------

Exhibition:	From:	To:	Stand N°:
-------------------	-------------	-----------	-----------------

Name of employee(e)	
First name	
Date of birth	
Address abroad	
Nationality	
Function on stand	
Duration of activity at PALEXPO from	to

Name of employee(e)	
First name	
Date of birth	
Address abroad	
Nationality	
Function on stand	
Duration of activity at PALEXPO from	to

Name of employee(e)	
First name	
Date of birth	
Address abroad	
Nationality	
Function on stand	
Duration of activity at PALEXPO from	to

Name of employee(e)	
First name	
Date of birth	
Address abroad	
Nationality	
Function on stand	
Duration of activity at PALEXPO from	to

Name of employee(e)	
First name	
Date of birth	
Address abroad	
Nationality	
Function on stand	
Duration of activity at PALEXPO from	to

Place and date:	Stamp and authorized signature:
.....

Switzerland



Mehrwertsteuer = MWST

Taxe sur la valeur ajoutée = TVA

Imposta sul Valore Aggiunto = IVA

Legal Base

As of 01.01.2018:

- 7.7% is the standard rate for most goods and services.
- 3.7% is the rate for hotels.
- 2.5% on certain exemptions as books, newspapers, food.

VAT was introduced in 1995.

Foreign companies must have a **fiscal representative** in Switzerland.

VAT-year

January 1 - December 31.

The application for refund must be submitted at the latest 6 months after the VAT-year has expired (June 30 the following year at the authorities). Therefore, the original invoices have to be sent to Cash Back VAT Reclaim AG **latest by April 15** the following year.

Enclosures to the application:

The claimant (client) must enclose the following documents:

- **Application** for VAT refund including **Power of Attorney**, (German, Italian and French versions accepted), filled in, signed and with company stamp (on the front side).
- **Certificate of VAT status**, original (a certificate from the official tax authority in his own country. This certificate has to correspond with the address on the invoices.
- **Original invoices**

Original invoices

Your invoices have to include the following details:

- Date incl. year.
- Name and address of the supplier.
- VAT number of supplier.
- **Name and full address of the company. Switzerland does not accept name lists.**
- VAT in percentage rate and amount.
- All invoices must be **machine printed** (handwritten is not accepted!!)

The invoices will be returned to you after the application has been verified by the authorities.

Minimum amount

CHF 500.-- VAT amount per application and year.

October 2017

© Cash Back VAT Reclaim AG (Copyright, all rights reserved)

THIS IS JUST A TRANSLATION!

**PLEASE ONLY USE THE GERMAN, FRENCH
OR ITALIAN APPLICATION FORM**

Application for VAT Refund

Foreign Claimant:

1. Full name of claimant or company name:

Full postal address:

City, Country:

2. Period of the application:

3. Code number in Switzerland:

(You can leave it empty)

4. Do you or a third party provide deliveries or services in Switzerland?

Yes, which ones?

No

5. Nature of business:

6. The representative certifies that the goods and/or services listed in this application were used by the claimant for the following activities:

.....

.....

7. Total amount of the application (CHF):

8. **Power of attorney**
The foreign company (named no. 1) hereby authorizes:

Company: **Cash Back VAT Reclaim AG**

Street: **Gewerbestrasse 11**

City: **CH-6330 Cham**

to act completely on our behalf until further notices in all matters pertaining VAT against the federal tax authorities in Bern

9. Place and date:

Company stamp and signature (legally valid)

Statement on the Tax Status (VAT)

The competent authority

.....

.....

.....

hereby certifies that

Name and address
of the company

.....

.....

nature of business

is registered as a VAT taxable company under the following VAT No

Place and Date

Signature, stamp and name of the
authority

Safety and security, fire prevention

Index

Page

1. Safety and security.....	17
1.1 Control centre, emergency number.....	17
1.2 Infirmary.....	17
1.3 Surveillance	17
1.4 Spaces to keep clear/safety zones	17
1.5 Safety of installations and technical equipment	17
1.6 Prevention of accidents at work.....	17
1.7 Hazardous products	18
1.8 Painting and solvents.....	19
2. Fire prevention and fire-fighting equipment	19
2.1 Fire extinguishers.....	19
2.2 Construction and decoration materials – standards to be observed regarding flammability	19
2.3 Gas cylinders provided by Users	20
2.4 Fuel tanks on Palexpo premises	20
2.5 Heat-generating appliances.....	20
2.6 Smoke-producing devices	20
2.7 Drones	20
2.8 Prohibition of circulating in the halls during events.....	20
Informative leaflet "Where am I authorised to fly my multicopter?"	21
"Fire Permit" - Form	23

1. SAFETY AND SECURITY

1.1 Control centre, emergency number

At the Palexpo Safety Service Centre, a computer continuously monitors information on the operation of the technical systems. Emergency calls should be made to the emergency number +41 (0)22 761 13 18 (ext. 1318).

1.2 Infirmary

There are two infirmaries at Palexpo:

- Halls 1 to 6: Service Centre or mobile infirmary
- Hall 7: Hall 7 Service Centre

Palexpo's health team, which is in direct contact with the region's hospitals, may be contacted by telephone through the Palexpo Control Centre by dialling:

Tel. +41 (0)22 761 13 18 (ext. 1318)
ou +41 (0)22 761 11 11 (ext. 999).

1.3 Surveillance

1.3.1 Private guard service

Any person providing a guarding, surveillance or security service must be accredited by:

**Commissariat de Police
Service des Armes, Explosifs et Autorisations (SAA)**

Nouvel Hôtel de Police
Chemin de la Gravière 5 P.O. Box 236
CH-1227 Les Acacias CH-1211 Geneva 8

Weapons / explosives: Tel.: +41 (0)22 427 79 60
Fax: +41 (0)22 427 77 41

Authorizations: Tel.: +41 (0)22 427 84 51
Fax: +41 (0)22 427 77 41

armes@police.ge.ch - www.ge.ch/police/

1.3.2 Theft risk

After the exhibition closes each day, it is in Users' interest to put valuable objects from the stand and small objects that could be removed easily in a safe place. Palexpo SA shall not be held liable in the event of theft.

1.3.3 Suspicious objects, threats

Any suspicious object found on or near a stand should be reported immediately to Palexpo's safety and security team, which will take the necessary measures.

Any personal threat should be reported promptly to the Palexpo's safety and security team, which will take action as unobtrusively as possible.

1.4 Spaces to keep clear/safety zones

A safety zone must be kept clear in front of the emergency exits in the doors of the halls; no goods may be stored in this zone, which must be free of all installations or raised floors.

Halls 1 to 6: A safety zone 4.00 m deep and 9.60 m wide

Hall 7: A safety zone 3.00 m deep and as wide as the doors

All halls:

Aisles leading to emergency exits must be completely straight, except in exceptional cases and after confirmation of the Palexpo's safety and security team.

Partitions closing off an exhibition area which is not against one of the walls of the hall shall have emergency exits leading into the safety corridors (plan available from the Palexpo's safety and security team).

All aisles must be at least 3.00 m wide, except for halls 2 and 4, which must be at least 4.00 m wide.

Emergency exits must remain closed throughout the exhibition and shall only be opened in the event of an emergency. Anyone using these doors when there is not an emergency shall be sanctioned. Palexpo SA reserves the right to withdraw the offender's access pass.

1.5 Safety of installations and technical equipment

All items for display or demonstration have to conform to the requirements set down in:

- the federal law of 12 June 2009 on the safety of products (LSPro; RS 930.11) and its implementing ordinance (OSPro; RS 930.111);
- SUVA/CNA's regulations on accident prevention.

Users must also comply with the ordinance of 19 December 1983 on the prevention of accidents and occupational disease (accident prevention ordinance, OPA – RS 832.30).

In case of doubt, Users should apply to the following body:

SUVA

Fluhmattstrasse 1
CH-6002 Lucerne
Tel.: +41 (0)41 419 51 11
Fax: +41 (0)41 419 58 28
www.suva.ch

SUVA - Division sécurité au travail
pour la Suisse Romande
Avenue de la Gare 23
CH-1001 Lausanne

Tel.: +41 (0)21 310 81 11
Fax: +41 (0)21 310 81 10
www.suva.ch

Furthermore, exhibitors are required to comply with instructions from Palexpo safety officers, who are empowered to modify or remove, at the User's expense, any installation or exhibit not in accordance with safety regulations. Palexpo shall not be held liable for any accidents or material damage.

1.5.1 Hazards due to ionising radiation

Any equipment with ionising radiation must comply with the provisions of the law on radiation protection (LRaP) and the ordinance on radiation protection (ORaP).

In particular, any use of equipment with ionising radiation must be reported to the Federal Office for Public Health (OFSP).

OFSP

Division Radioprotection
CH-3003 Berne
Tel.: +41 (0)58 462 21 11
Fax: +41 (0)58 462 21 11

1.6 Prevention of accidents at work

Any person present on the Palexpo site will spontaneously take the necessary measures to comply with the rules applicable to the prevention of accidents at work.

In this respect, Palexpo SA draws attention to the following specific provisions:

- the MSST Directive and the associated measures concerning the use of doctors and other occupational safety specialists apply to any company and the people such company calls upon;
- It requires coordination with the various parties involved so that everyone can work in complete safety;
- SUVA offers a multitude of resources on its website, particularly concerning vital rules, at www.suva.ch;
- the provision of personal protective equipment (EPI) for workers is specifically regulated, in particular by the Accident Insurance Act. For example, certain requirements apply in relation to the wearing of helmets and safety shoes, although it should be noted that the EPI requirements vary according to the potential risks involved;
- activities related to aerial platforms, lifting equipment and scaffolding systems are very strictly regulated. In general, a proper permit is required and full compliance with licensing requirements and safety rules is mandatory.

1.6.1 Welding

(See the regulations of the Swiss Welding Association – hereinafter referred to as ASS)

For all hot work (welding, grinding, and metal-cutting), Users must fill out a fire permit (form on page 27) before beginning work. The permit must be approved by Palexpo's safety and security team.

Due care must be taken to prevent gas cylinders from falling. Collars, chains and straps are appropriate means of securing them. Gas and fumes must be drawn off at source and evacuated without endangering the surroundings.

Support racks conforming to ASS regulation 541.1 must be fitted to pressurised gas cylinders that are part of welding equipment (see ASS leaflet 590.1).

Gas-welding stations must conform to ASS regulation 690.1.

Manual electric arc manual installations are governed by ASS regulation 690.2.

Welders and their assistants must wear appropriate clothing, as well as eye protection fitted with normalised tinted lenses (see Suva forms 67104, 67103 and 44091).

Particle-filter masks are used to protect welders from fumes and dust. These masks are necessary when the particles emitted by the relevant processes are small (<1mm).

When there are welding fumes, it is advisable to use a Category P2 particle filter or a half-mask with a Category FFP2 filter as per EN 143/EN 149 (see Table 2, Form 44503, page 31 of the Suva).

Details of the above are obtainable from:

SUVA

Division sécurité au travail pour la Suisse Romande
Avenue de la Gare 23
CH - 1001 Lausanne

Tel.: +41 (0)21 310 81 11

Fax: +41 (0)21 310 81 10

www.suva.ch

or

ASS

Association suisse pour la technique du soudage

St. Alban-Rheinweg 222

CH - 4052 Basel

Tel.: +41 (0)61 317 84 84

www.svsxass.ch

Technical documents may be ordered from SUVA

<https://www.suva.ch/fr-ch/prevention>

Tel.: +41 (0)41 419 51 11

1.6.2 Working at height

During construction, assembly, repair or maintenance work, top priority must usually be given to the use of scaffolding with safety walls or nets.

The User and the company engaged to carry out the installation are jointly and severally responsible for the good condition of the system.

In the absence of such collective fall-prevention measures, anyone working at height must wear a suitable safety harness or fall protection device with an attachment point appropriately positioned to limit the fall factor (see form SUVA 44002 on roping up for safety).

The area beneath the work must be closed to the public and secured (danger of falling objects).

Ladders are primarily temporary forms of access. Only light tasks that do not generate high horizontal forces may be carried out from a ladder. The execution of tasks that cover large surfaces is limited to a working height of 5 metres. Preference will be given to the use of wheeled or cradle scaffolding for tasks to be performed at height (see form Suva n° 44026).

Technical information is available on the site <https://www.suva.ch/fr-ch/prevention>.

Palexpo SA accepts no liability in the event of an accident.

1.7 Hazardous products

1.7.1 Hazardous substances

The use of hazardous products is regulated by the federal law of 5 June 2015 on protection against hazardous substances and preparations (law on chemical products, Lchim - RS 813.11), which came into effect on 1 August 2015, and its implementing ordinances. The purpose of Lchim is to protect health, the environment and workers.

Various information relating specifically to Lchim (official certification, classification, labelling etc.) is available on the site of the Swiss Society of Toxic Substance Inspectors (ChemSuisse) at www.chemsuisse.ch/ (available in French and German only).

On the whole, the law no longer provides for authorisations for Users, except for certain professional or commercial uses of specific products, such as crop protection products, pesticides, public swimming pool water disinfectants and wood preservatives where a permit is required.

Nevertheless, companies and educational establishments in which hazardous substances or preparations are used for professional or commercial purposes must designate one person (contact person) accountable for use according to the regulations and able to provide the executing authorities with all the necessary information. This person must have the necessary qualifications both at the technical level and in terms of operations. The person's name must be communicated to the Cantonal Pharmacist's Office.

Service du pharmacien cantonal (SPC)

Section des toxiques et des substances dangereuses pour l'environnement

Avenue de Beau-Séjour, 24

CH-1206 Geneva

Tél.: +41 (0)22 546 51 88

section.toxiques@etat.ge.ch

For labelling in accordance with Regulation (EC) No. 1272/2008 (CLP/GHS Regulation), the following hazard pictograms must be used depending on the classification of the substances or preparations (mixtures).



These products may be exhibited at a trade fair or exhibition subject to the following conditions:

- direct sale on stands is prohibited. Orders may be taken only from craft organisations and industry;
- Users must hold a general permit issued by the Inspectorate of the canton in which they are domiciled or, if they are not Swiss, from the Toxic Substances Department of the Cantonal Pharmacist's Office for the canton of Geneva, following approval of the products they wish to exhibit by the Toxic Substances Division of the Federal Office of Public Health in Bern;
- Users must store substances and preparations in a way that takes account of the instructions on the packaging and, where applicable, on the safety data sheet, which must be retained for as long as the product is in use. This safety data sheet must be easily accessible in case of accident.

Hazardous substances and preparations must be stored safely according to their level of risk. In particular, they must:

- be protected against hazardous external influences;
- be inaccessible to non-authorized persons;

be stored in a clear and tidy manner, separately from other goods. Any form of storage in the immediate vicinity of foodstuffs, animal feed or therapeutic products is prohibited.

Substances and preparations likely to generate hazardous reactions if they interact (incompatible products) must be stored separately from one another.

As regards the use and storage of chemical products, please refer to the technical provisions issued by CFST (regulations on safety at work). These include regulation no. 6501 on acids and alkalis; regulation no. 1825 on flammable liquids and regulation no. 1942 on liquefied gases.

These documents are available on <https://www.suva.ch/fr-ch/prevention>.

1.7.2 Ozone-depleting substances

The use and importation of such substances (CFC, HCFC, Halons, Trichloroethane, etc.) are prohibited in Switzerland, or otherwise subject to regulation.

Exhibitors are requested to apply to the competent authority if they require any additional information:

Service du pharmacien cantonal
Section des toxiques et des substances dangereuses pour l'environnement
Avenue de Beau-Séjour 24
CH-1206 Geneva

Tél.: +41 (0)22 546 51 88
section.toxiques@etat.ge.ch

Users shall be solely and fully liable for the consequences of any failure to act in accordance with the requirements set down in the laws and ordinances mentioned above.

1.8 Painting and solvents

The storage and handling of flammable liquids must be in compliance with CFST regulation no. 1825 and the risk of explosion contained according to the provisions of SUVA information sheet no. 2153. When painting with a spray gun, all precautions listed in SUVA ordinance no. 1731 must be taken.

Users are responsible for ensuring that solvent vapours or dust deposits do not affect neighbouring stands. Work of this nature should be carried out at night so as not to disturb staff on adjacent stands.

Chemical substances used on the Palexpo site must be stored safely, take into consideration risks of dangerous interactions with other substances and be protected from the dangerous interactions risks of fire, theft and poisoning.

Special authorisation from Palexpo's safety and security team is required for storage of quantities larger than 50 kg.

The cost of destroying abandoned waste or chemical residues shall be borne by the User.

At the User's request, Palexpo's Exhibitor Relations Office can arrange for waste disposal. Waste must not be poured into wash basins or toilets.

If labelling is incomplete, unclear, or in a foreign language, Users should ask Palexpo's Exhibitor Relations Office for assistance.

Exhibitors are advised to use water-based products.

Rigorous inspections will be carried out to ensure that all these provisions are observed, in everyone's interest.

2. FIRE PREVENTION AND FIRE-FIGHTING EQUIPMENT

Users are advised to inspect their stands at closing time each day as a precaution against fire caused by any heat source or electrical installations..

2.1 Fire extinguishers

Palexpo's safety and security team can require fire extinguishers to be fitted to stands on which the materials or objects exhibited constitute a high fire risk. The type and number of extinguishers shall be determined by the safety and security team, and shall then be leased at the published price for the duration of the exhibition. They must be returned after the event.

2.2 Construction and decoration materials – standards to be observed regarding flammability

The following official authority is appointed to check building and decoration materials, in accordance with the current legislation:

Police du feu
Rue David-Dufour 5
Case postale 22
1211 Genève 8
Tel.: +41 (0)22 546 66 22
Fax: +41 (0)22 546 66 39
policedufeu@etat.ge.ch

At any time, it may require flammability classification certificates to be produced for each class of material.

In case of non-compliance, it can order dismantling of the stand. Any person contravening the regulations will be liable to the relevant police fines.

As a general rule, the following materials must have classification according to the Swiss or European EN 13501-1 standard.

Reaction to fire class	Critical reaction	Classification to the SN EN 13501-1 standard		
		Construction products	Thermal insulation for linear pipes	Floor Coverings
RF1		A1 A2-s1, d0	A1 _L A2 _L -s1, d0	A1 _{fl} A2 _{fl} -s2
RF2	cr	A2-s1,d1 A2-s2,d0 A2-s2,d1 B-s1,d0 B-s1,d1 B-s2,d0 B-s2,d1 C-s1,d0 C-s1,d1 C-s2,d0 C-s2,d1	A2 _L -s1,d1 A2 _L -s2,d0 A2 _L -s2,d1 B _L -s1,d0 B _L -s1,d1 B _L -s2,d0 B _L -s2,d1 C _L -s1,d0 C _L -s1,d1 C _L -s2,d0 C _L -s2,d1	B _{fl} -s1 C _{fl} -s1
		A2-s1,d2 A2-s2,d2 A2-s3,d0 A2-s3,d1 A2-s3,d2 B-s1,d2 B-s2,d2 B-s3,d0 B-s3,d1 B-s3,d2 C-s1,d2 C-s2,d2 C-s3,d0 C-s3,d1 C-s3,d2	A2 _L -s1,d2 A2 _L -s2,d2 A2 _L -s3,d0 A2 _L -s3,d1 A2 _L -s3,d2 B _L -s1,d2 B _L -s2,d2 B _L -s3,d0 B _L -s3,d1 B _L -s3,d2 C _L -s1,d2 C _L -s2,d2 C _L -s3,d0 C _L -s3,d1 C _L -s3,d2	B _{fl} -s2 C _{fl} -s2

The use of materials is restricted owing to their critical reaction to fire or clear flammability.

The flammability class is determined by an approved laboratory under clearly specified conditions, and reported officially.

Addresses of approved laboratories:

TÜV SUED
Swiss Process Safety GmbH
Mattenstrasse 24a
CH-4002 Basel
Tel.: +41 (0)58 517 80 20

Time required: 1 week

Laboratoire Implenia S.A.
Rte de Bois-de-Bay 67
Case postale 65
CH-1242 Satigny
Tel.: +41 (0)58 474 26 20
www.implenia.com

Time required: 1 to 2 days

2.2.1 Quick test

A quick test to classify the flammability of a substance can be performed as follows:

- cut a sample about 15 cm in length;
- apply the flame of a normal cigarette lighter to the cut edge for 20 seconds.

If combustion ceases as soon as the flame is removed (i.e. self-extinguishing), the material can probably be classed as difficult to burn or fireproof. It is advisable to repeat this quick test several times

2.2.2 Tip

Even if the supplier guarantees that the material is non-flammable, it is advisable to carry out the above test to avoid unpleasant surprises later.

2.2.3 Important

In the event of legal proceedings, only an official report from an approved laboratory shall be accepted as evidence.

2.3 Gas cylinders provided by Users

Users wishing to use gas cylinders must inform Palexpo's safety and security team, who shall perform an inspection on-site.

Gas cylinders must be properly secured (with a chain) to eliminate all risk of falling over.

The connecting pipes must be fitted in accordance with best practice (see form Suva n° 33030 and 67068).

The following conditions must therefore be satisfied:

- pipes must be gastight;
- pipes must be pressure-resistant (minimum bursting pressure 60 bar);
- flexible hoses must be no longer than 1.50 m, and their expiry dates must not be exceeded.

Users must not keep more than two cylinders in reserve on the stand.

Users wishing to replace or refill them must inform Palexpo's Exhibitor Relations Office.

It is prohibited to store cylinders (whether in use or in reserve) outside the stand.

Adapters for all kinds of connections and plugs are available on-site.

2.4 Fuel tanks on Palexpo premises

To eliminate explosion risks, the regulations on the following exhibits must be obeyed:

2.4.1 Thermal and electrical vehicles

Tanks may not contain more than 2 litres of fuel.

Under all circumstances fuel tanks must be locked and leakproof.

2.4.2 Planes/helicopters

Tanks may only contain the minimum fuel needed to fly between Geneva International Airport and Palexpo, if such a flight is to be made as part of the exhibition.

Under all circumstances fuel tanks must be locked and leakproof.

2.4.3 Vehicles with internal combustion engines

Any holder of an internal combustion vehicle wishing to park on the Palexpo site must obtain an authorisation from the safety and security team and have the vehicle monitored by a security agency approved by Palexpo SA.

2.5 Heat-generating appliances

Heat-generating appliances such as boilers, cookers and grills must comply with and be installed according to best practice, and meet the relevant operating requirements.

In addition, they must be equipped and installed so as to prevent contact with the clothing of passers-by.

Grills must be fitted with an extractor hood containing an activated carbon filter

2.6 Smoke-producing devices

All forms of pyrotechnics are prohibited.

If appropriate, the Organiser of an event may, taking due account of circumstances and location, authorise an exhibitor to let off artificial fog or smoke, but only with the explicit agreement of the safety and security team, to whom the final programme must be submitted for approval.

2.7 Drones

The use of drones and multicopters must satisfy the requirements of the Federal Office of Civil Aviation (FOCA) and the relevant legal basis.

- Ordinance on Special Category Aircraft (OACS)
<https://www.admin.ch/opc/en/classified-compilation/19940351/index.html>
- Federal Act on Data Protection (FADP)
<https://www.admin.ch/opc/en/classified-compilation/19920153/index.html>

Contacts

Federal Office of Civil Aviation (FOCA)

Tel.: +41 (0)58 465 80 39 (Tuesday and Thursday: 08h00 - 12h00)

Fax: +41 (0)58 465 80 32

rpas@bazl.admin.ch

The FOCA has created an informative leaflet outlining the basic rules to be followed when using multicopters and other minidrones.

All requests for authorisation to fly drones within Palexpo's halls must be approved by Palexpo's Security Team in advance.

2.8 Prohibition of circulating in the halls during events

All vehicles (one wheel or more) with manual, mechanical or electric propulsion are prohibited in the buildings and halls of Palexpo during events. The only exceptions are vehicles for people with reduced mobility and strollers.



Federal Office of Civil Aviation

When is the use of multicopters allowed – and when is it prohibited?

.....

Operation without the need for a permit



Remote controlled multicopters with a total weight of less than 30 kilograms and in permanent direct eye contact of the "Pilot"



Multicopters on model airfields and operated by participants in air shows



Multicopters on open ground and in populated areas without gatherings of people (groups of more than two dozen people). Always observe the principle of protection of privacy and never operate a drone in a nature conservation area.
-> (See RPAS Map)

Operation requiring a permit



Multicopters controlled with video goggles and without a second "pilot" in permanent direct eye contact



Multicopters with a total weight of more than 30 kilograms

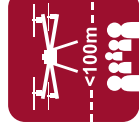

Multicopters within a radius of less than 100 metres around gatherings of people outdoors, except at public air shows and on designated airfields for flying model aircraft



Multicopters operated within a radius of less than 5 kilometres around airfields / airports, and at an altitude higher than 150 metres above ground level in air traffic control zones; here the necessary permit has to be obtained from the airfield manager or air traffic control
-> (See RPAS Map)



Please observe any other applicable cantonal or municipal restrictions and temporarily restricted airspace (e.g. above Davos during the World Economic Forum).

Contact

RPAS Map: www.bazl.admin.ch/karte-rpas

E-mail: rpas@bazl.admin.ch

Further information: www.bazl.admin.ch/rpas



Fire Permit

With the submission of this document, the person signing it (chief executive of the company or his/her representative) confirms that he/she has, in advance, taken all necessary steps to check on the layout of any hot work spots and their proximity to potential problem areas and/or substances during the work (specific risks) as well as to the chosen materials.

CONSTRUCTION

- starting date
.....
- date of completion (or maximum duration):
.....
- description of intended work
.....
.....
.....
.....
- starting time:..... / completion:.....
- location:
- enterprise or service organization performing the work:
.....
- list of authorized operators:
.....
.....
.....

Mandatory validation

- in case of hot work construction of less than 1 day
name:
- in case of hot work construction involving additional sites
name:

Type of hot work construction

- welding
- brazing
- cutting
- grinding
- other
.....

Materials used

- welding station
- blow torch
- laser
- circular/reciprocating/chain saw
- other
.....

SPECIFIC RISKS

- (concerning products, procedures, inventory, ...)
-
-
-
-
- Proximity to Atex zone (explosive atmosphere area)

Related documents

- prevention plan
-
- work authorization
-
- access permits
-

SAFETY MEASURES

	NO	YES	DONE
Evacuation of combustible substances			
Fencing / separation of work zone			
Protection of non-movable equipments / objects			
Condamnation (source of energy, flow of materials, ...)			
Dumping - Cleaning - Dusting			
Evacuation of gases (pipes, basin, tank, ...)			
Insulation of pipes			
Removal of pipes			
Delimiting of interstices			
Securing (equipment, gutters, basins, ...)			
Insulation of sprinkler loop sensors			
Insulation of sprinkler system			

PREVENTION MEASURES

	NO	YES	DONE
Protection of surroundings - screens, panels - fireproof covers - water - sand - -			
Forced ventilation			
Vapor control - explosimeter - oxygen content - gas detector -			
Fire fighting measures: <i>in addition to any existing measures</i> - fire extinguishers: number: type: - active water valve / fire hydrant - fire hose			

SAFETY SUPERVISION

- during construction:
 name: signature:
- after construction from h until h
 name: signature:

ALARM IN CASE OF FIRE OR ACCIDENT

- Location of alarm devices:
-
 -
 -

EMERGENCY NUMBERS

- Fire department: **118**
- Contact in case of accident or fire: **Safety Services Palexpo**
- Telephone: **+41 22 761 13 18**

Persons or services	Name	Function	Signature
- Person in charge			
- Safety			
- Contact for work performed			

Fire permit granted on (date):

Signature of executive of exhibitor company
 or his/her qualified representative:

Regulations for construction

Index

Page

1. Technical data for Palexpo	26
1.1 Connection of utilities to stands	26
1.2 Floor loads (admitted: 1 kg = 10 N).....	26
1.3 Access-ramp loads	26
1.4 Floors of the halls.....	27
2. Stand building	27
2.1 General recommendations.....	27
2.2 Floor fixings.....	27
2.3 Wall fixings.....	27
2.4 Construction method	27
2.5 Rigging.....	27
2.6 Advertising displays and official information displays	28
2.7 Air conditioning (stands, conference rooms, lounge rooms, offices, etc.).....	28
2.8 Through-stand aisles leading to an emergency exit.....	28
2.9 Structures overhanging aisles	28
2.10 Exits	28
2.11 Glazing.....	28
2.12 Turntables	29
2.13 Balloons	29
2.14 Laser equipment, classes 1M, 2M, 3R, 3B and 4	29
2.15 Hazards due to ionising radiation	29
3. Multi-storey structures / Complex constructions (bleachers and high structures)	29
3.1 Approval of plans.....	29
3.2 Loading calculation for structural components	29
3.3 Permissible local stress on the floor of Halls 4 and 5	30
3.4 Lifts - Temporary equipment for the transport of people	30
3.5 Stairways/Gangways/Platforms	30

1. TECHNICAL DATA FOR PALEXPO

1.1 Connection of utilities to stands

General rules on technical connections at Palexpo

Connection points are located in connection boxes at floor level. These boxes are indicated on the hall plans by the following symbols:

 = Electricity + Telecommunication + Radio + Television

 E = Water and drainage

 A = Compressed air

 E = Water

NB: Halls 6 and 7 have a network of cable ducts connecting the floor boxes.

These ducts are shown on the plan.

Exhibitors are strictly forbidden to make their own connections to the floor boxes.

Floor boxes that are in use must be accessible at all times.

It is forbidden to touch the electrical equipment at the goods entrances.

In the event that the User does not use the hall lighting to substitute it with his own system, he must monitor the voltage to allow automatic activation of the emergency lighting installed by him on his lighting network. Palexpo SA and its subcontractors must have access to the User's installations for inspection.

Electrical equipment on the stands must comply with the Swiss law on electrical equipment (LIE), the ordinance on low-voltage equipment (OIBT) and Section 7, Chapter 11 of the Swiss standard on low-voltage equipment (NIBT), as well as with all laws and regulations in force in Switzerland.

Electrical equipment on stands shall be monitored by an official inspector with the legal authority to require alterations to be made to the equipment if these are necessary for compliance with the laws, standards and regulations listed above, this includes emergency power supplies and emergency lighting as well as evacuation signs.

Based on the inspector's recommendations, Palexpo SA reserves the right to cut the power supply to any stand in the event of refusal to adapt the electrical equipment to ensure compliance.

Users shall bear the cost of adapting equipment that does not comply with the regulations.

Users shall be liable for any technical faults or damage that may result from non-compliance with the provisions laid down by Palexpo SA.

Users may not object to cables and pipes being laid over their stand site to supply neighbouring stands, if necessary.

Modular raised flooring consisting of standard wood frames may be rented from Palexpo to facilitate the passage of cables (see relevant order form).

In areas open to the public, a raised floor is essential for covering high-voltage electricity cables and water supply and discharge pipes.

Users must specify that their stand contractor use NON-SLIP materials to ensure that floors, floorings and other surfaces, including aisles and stairs, have non-slip surfaces.

1.1.1 Electricity supply

Stands' electrical equipment, on the ground and on the superstructure, must comply with:

- the Swiss law on electrical equipment (LIE);
- the ordinance on low-voltage equipment (OIBT);
- and the Swiss standards on low-voltage equipment (NIBT).

Stands may only be connected to the **power supply** by Palexpo SA, as per the NIBT, Chapter 7.11, **Exhibitions, shows and stands**:

According to Article 7.11.4.6.2, Disconnection:

All temporary structures, such as vehicles, stands or entities, which are to be occupied by a specific User and all distribution circuits supplying external equipment must be equipped with their own disconnection switches, which must be easily accessed and identified. (...)

Electrical control panels are fitted to each stand.

Electrical equipment on stands shall be inspected by official inspection firm Sécurelec SA, which has the legal authority to require alterations to be made to the equipment if these are necessary for compliance with the laws, standards and regulations listed above.

Based on the inspector's recommendations, Palexpo SA reserves the right to cut the power supply to any stand in the event of refusal to adapt the electrical equipment to ensure compliance.

Users shall bear the cost of adapting equipment that does not comply with the regulations.

It is forbidden to touch the electrical equipment at the goods entrances.

1.1.2 Superstructure

The electrical panels in the superstructure must be placed on the platform closest to the stand in order to be accessible at all times. The wiring of the boards up to the stand will be charged to the User.

1.2 Floor loads (admitted: 1 kg = 10 N)

The following load limits apply:

1.2.1 Entrance hall, Conference Centre, Hall 3 and lobby

A uniformly distributed average load of

$$\rho = 4000 \text{ N/m}^2 = 4 \text{ kN/m}^2.$$

1.2.2 Halls 1 and 2

A uniformly distributed average load of $p = 5 \text{ kN/m}^2$, which may be replaced with one of the following variants, over an area of $9.60 \text{ m} \times 9.60 \text{ m}$:

- a) two concentrated 180 kN loads + one uniformly distributed load of 1 kN/m^2 ;
- b) two axles of 180 kN + one uniformly distributed load of 1 kN/m^2 ;
- c) one load of 240 kN, including live load + one uniformly distributed load of 2.5 kN/m^2 ;
- d) two axles of 120 kN + one uniformly distributed load of 2.5 kN/m^2 .

1.2.3 Hall 4

A uniformly distributed average load, similar to that allowed for road surfaces. For all loads exceeding 10 kN/m^2 , the User must obtain permission from Palexpo SA's Operations Department, which will, if necessary, seek the expert advice of the civil engineering firm T Ingenierie SA.

1.2.4 Hall 5

A uniformly distributed average load of 10 kN/m^2 , which may be replaced by one of the following alternatives, over areas of $9.60 \text{ m} \times 7.20 \text{ m}$ or $7.20 \text{ m} \times 7.20 \text{ m}$:

- a) two concentrated loads of 180 kN + one uniformly distributed load of 4 kN/m^2 ;
- b) two axles of 180 kN + one uniformly distributed load of 4 kN/m^2 ;
- c) one load of 240 kN, including live load + one uniformly distributed load of 6 kN/m^2 ;
- d) two axles of 120 kN + one uniformly distributed load of 6 kN/m^2 .

1.2.5 Hall 6

A uniformly distributed load of max. 20 kN/m^2 , which may be replaced with concentrated loads of max. 500 kN spaced on a 7-m grid and giving a residual floor load of 5 kN/m^2 .

1.2.6 Hall 7

A uniformly distributed average load of 10 kN/m^2 , which may be replaced by one concentrated load of 240 kN including live load, plus one load of 6 kN/m^2 , uniformly distributed over an area of $7.20 \text{ m} \times 7.20 \text{ m}$ around the concentrated load.

1.2.7 Bars 5 and 6

Max. permitted roof load: 5 kN/m^2 .

1.3 Access-ramp loads

The access ramp to Halls 1 and 2, gates 11, 18, 21 and 28, on the Lyon side, can carry two 180 kN axles per 9.60 m span.

The access ramp to Halls 4 and 5, gates 41, 48, 51 and 58, on the Lyon side, can carry two 180 kN axles per 9.60 m or 7.20 m span respectively.

The access ramps to Halls 5 and 6, gates 54, 55, and 617 to 624, on the Lausanne side, can accept the normal loads for roads and bridges subject to normal load tolerances (Article 9, SIA standard 160, 1970 edition).

1.3.1 Special equipment

Permission must be obtained from Palexpo SA's Operations Department for any special equipment, such as crane trucks or lifting gear, of which the weight exceeds one of the load limits specified above. If necessary, the expert opinion of the relevant civil engineering office will be sought:

- a) For Halls 1 to 6:

T Ingénierie SA

Quai du Seujet 18
CH-1201 Geneva

Tel.: +41 (0)22 716 08 00

Fax: +41 (0)22 716 08 99

gva@t-ingenierie.com

www.t-ingenierie.com

- b) For Hall 7:

INGENI SA Ingénierie Structurale

Jérôme Pochat, Ingénieur civil HES
Rue du Pont Neuf 12
CH-1227 Carouge/Geneva

Tel.: +41 (0)22 308 88 88

Mobile: +41 (0)79 310 66 24

jerome.pochat@ingeni.ch

www.ingeni.ch

1.4 Floors of the halls

Given the large surface area of the halls, the floor is not uniformly level. Palexpo SA declines any responsibility for this.

2. STAND BUILDING

2.1 General recommendations

Stands must conform to basic safety standards and must not present a danger to occupants or visitors, or to the immediate environment.

Users are responsible for the construction and decoration of their stands. They should refer first to the rules of the exhibition, which prevail.

All Users must ensure that they know the location, dimensions and layout of the stand allocated to them. Palexpo SA's Operations Department can arrange visits.

Please also refer to the section Safety and security/Fire prevention.

Technical plans for stands must be submitted for approval in metric measurements.

The general plan of the exhibition with the location of each exhibitor must be submitted to Palexpo SA at least 6 weeks before the opening of the event, the general technical plans at least 4 weeks before the opening of the event and the specific technical plans with the last changes minimum 2 weeks before the opening of the event. Beyond these deadlines Palexpo SA no longer guarantees the execution of the work.

2.1.1. Stands in Hall 2 that are against the railing above Hall 4

For multi-storey stand constructions located at the railing above Hall 4, a net must be fitted to prevent objects from falling during assembly and dismantling.

2.2 Floor fixings

The design and construction of the stands must render them self-supporting – in other words, they must not need to be attached to the floor or the walls of the Palexpo buildings.

2.2.1 All halls

It is strictly prohibited to make holes in the floor.

2.2.2 Entrance hall, Hall 3, Conference Centre, lobby and main entrances' outdoor esplanade

Sticky tape and adhesive stickers may not be applied to the floor.

Plants put on the marble floors should be in leaktight pots. The cost of removing water stains by thorough polishing shall be borne by the User.

2.3 Wall fixings

2.3.1 Entrance hall, Conference Centre, lobby and main entrances' outdoor esplanade

It is forbidden to fix anything to the walls, the floor or the ceiling.

2.3.2 Halls 1, 2, 3, 4, 5, 6 and 7

It is strictly forbidden to attach anything at all to the floors, partitions, walls, ceilings or structural elements of the Palexpo buildings.

It is also forbidden to carry out welding or soldering work that affects the metallic structures of the building and to attach anything whatsoever to these.

2.4 Construction method

During stand construction, all woodworking tools (saw, planer, sander, etc.) that produce chips or dust must be connected to a dust collection system.

2.5 Rigging

2.5.1 Entrance hall, Hall 3, lobby and main entrances' outdoor esplanade

Rigging is not allowed.

2.5.2 Conference rooms A, B and C

A certain number of rigging points are fixed in the false ceiling. Rigging is not allowed from any other points. Furthermore, the maximum load permitted will depend on the occupancy of Hall 1.

2.5.3 Halls 1, 2, 4, 5, 6 and 7

Rigging points may be installed from the metal framework of Halls 1 to 6 or from the existing rigging hooks of Hall 7 wooden framework, provided that they are set by Palexpo SA's Operations Department and a plan giving the following details for each rigging point has been submitted:

- The distance from the edge of the stand;
- The height from the floor of the hall;
- The weight.

In borderline cases, approval shall only be given if notice is received from the relevant civil engineering firm.

Halls 1, 2, 4, 5 and 6

Loads rigged from the metal framework must not exceed a total average value of 30kg/m².

The maximum weight per rigging point without an engineering study is 1,000kg.

The maximum weight per rigging point with an engineering study is 2,000kg.

Height of rigging points in Halls 1 and 2:

Maximum height 11.70m (except underneath the walkways of towers 1-2-5-6-9-10, where the height is 11.30m).

No elements (except rigging points) may be suspended inside the Palexpo superstructure beyond 11.50m.

Height of rigging points in Halls 4,5 and 6:

Maximum 17.70m (except underneath the walkways of towers 9-10-13-14-17, where the height is 17.30m).

No elements (except rigging points) may be suspended inside the Palexpo superstructure beyond 17.50m.

Hall 7

Autorisation must always be requested from Palexpo SA's Operations Department before suspending a load from the framework of Hall 7.

The maximum weight per rigging point is 1,000kg.

No 2,000kg attachment points are authorised, even with an engineering study.

Height of the rigging point: maximum 10m (except on the highway side, under the ventilation duct, where points are set at maximum 9.30m).

2.5.4 Standards for all halls

Rigging must always be performed in line with the static loading safety standards applying in Switzerland. The working standard applied by Palexpo SA is the same as that applied throughout the European exhibition sector, as set out in Article 4 of the law of 18 December 1992.

All chains and accessories must have a safety coefficient of 4 of maximum working loads (MWLs).

All slings and shackles must have a safety coefficient of 5 MWLs: cables for 1T points must have a diameter of 10mm and cables for 2T points must have a diameter of 14mm. The shackles used are 1.5T shackles for 1T attachment points and 3T shackles for 2T attachment points.

All textile slings must have a safety coefficient of 7 WMLs.

Palexpo SA applies the legally recognised EU standard.

If, for contractual or customer-specific reasons, Palexpo SA has to apply a higher standard than the one in force, the costs incurred by this higher standard will be invoiced to the exhibitor or manufacturer. Under no circumstances will Palexpo SA apply a lower standard than the one in force.

The installed rigging point depends on the load announced by the customer.

Palexpo SA declines all liability if, for reasons beyond its control, the work could not be carried out before the deadline stated on the order form.

Rigging work is carried out at the Users' risk.

Palexpo SA is only liable for the rigging cables it installs until the attachment ring. However, Palexpo shall not be held liable for damage caused by a falling object rigged in a way that did not meet safety standards.

All work shall be invoiced according to time expenses, even if a cost estimate was submitted for it in advance.

2.5.5 Canopies/False ceilings

Special authorisation must be obtained from Palexpo SA's Operations Department for the rigging of canopies and false ceilings to ensure that ventilation duct outlets are not obstructed.

2.5.6 Lifting devices

It is prohibited to work within the Palexpo venue with one's own lifting engine. Lifting devices, regardless the origin, (scissors lifts, telescopic, articulated cherry pickers etc.) are provided and rented exclusively by the services of Palexpo.

2.6 Advertising displays and official information displays

When building the stand or performing any construction work, it is forbidden to completely or partially hide advertising displays or official information displays.

2.7 Air conditioning (stands, conference rooms, lounge rooms, offices, etc.)

Any air exchange installation is prohibited for reasons of thermal load. Only water cooling systems connected to the Palexpo chilled water system are allowed.

The connection of air conditioners to the drinking water network is prohibited by the law on Energy (18 September 1986)
https://www.ge.ch/legislation/rsg/f/s/rsg_l2_30p01.html.

In case of infringement, a fine of CHF 2'000.- per device will be charged to the responsible User and the installation will be decommissioned.

2.8 Through-stand aisles leading to an emergency exit

See also the section Safety and security/Fire prevention, Article 1.4, Spaces to keep clear/safety zones.

2.8.1 Carpets

When a public aisle crossing a stand leads straight to an emergency exit, Users may cover the floor with a plain carpet (no identification, no publicity) of their choice.

This carpet must:

- be of a contrasting colour;
- or be marked at the edges by strips of a different colour or by studs of at least 10 cm in diameter in a contrasting colour to the surrounding floor, set no more than 70 cm apart.

Whatever method is used, the public aisle must be easily identified as such in the view of Palexpo SA's safety and security team and upon inspection by the fire service of the Department of Planning, Housing and Energy (DALE) of the Canton of Geneva.

2.8.2 Other aisle coverings

All other aisle coverings must be clearly shown on the stand layout drawings: these require prior authorisation by Palexpo SA's Operations Department, which is responsible for maintaining optimal conditions for free movement in the halls, in the interest of all users.

For your information, the minimum requirements are as follows;

a) Quality of materials and their installation:

The overall structure of the gangway covering, including an access ramp with a 6% gradient, must be capable of carrying loads of 8 tonnes per wheel to allow fully loaded vehicles of any type to use the aisle.

b) Height of flooring:

- The height of the flooring may reach a maximum of 15 cm as long as this matches the height of the flooring of the stand bordering the aisle;
- Users are urged to seek agreement with adjacent standholders, where necessary, for adjusting the heights of their floorings, or for installing a connecting ramp;
- The flooring must have a clean finish and a ramp with a 6% gradient at both ends;
- This flooring should not bear any identification or advertising.

2.9 Structures overhanging aisles

The lowest point of structures overhanging aisles must be at a minimum height of:

- 3.20 m from hall floor, if the structures overhang aisles leading to logistics doors;
- 2.50 m from hall floor, for other aisles.

2.10 Exits

Stands in which a number of people can be accommodated, either in a multi-level structure or a closed space, must have the following escape routes:

- up to 50 people:
one exit, 0.90 m wide;
- up to 100 people:
two exits, each 0.90 m wide;
- up to 200 people:
three exits, each 0.90m wide, or two exits, one 0.90m wide and the other 1.20 m wide;
- more than 200 people:
two or more exits at least 1.20 m wide, where the total exit widths must be at least:
 - on the ground floor: 0.60 m wide per 100 people or part thereof;
 - on the upper floors: 0.60 m wide per 60 people or part thereof.

The number of people per level, to be computed on the basis of one per square metre, is defined by the surface area of this level (the area enclosed by its perimeter), less 15 % allowance for installations.

In addition, the lighting and marking of emergency exits must conform to current safety regulations.

See also Article 3.5, Stairways/Gangways/Platforms.

2.11 Glazing

All glazing must be designed in safety glass, either laminated or tempered, covered with film or with visualisation elements and must conform to Swiss construction standards.

2.12 Turntables

Turntables must be designed and operated in such a way as to avoid creating any risk of an accident. Their perimeters must be closed off so that fingers or loose clothing cannot be caught in the machinery.

2.13 Balloons

Balloons may be allowed under the following conditions:

- helium-filled balloons (no other gas is allowed) are permitted for decoration purposes only;
- for all other uses (distribution, etc.) only balloons filled with compressed air are allowed.

Under all circumstances, Users must request authorisation from the Organiser and from Palexpo Sa's safety and security team.

If balloons have to be recovered from the ceiling, the cost of the manlift shall be invoiced by the hour.

2.14 Laser equipment, classes 1M, 2M, 3R, 3B and 4

The use of laser beam equipment of classes 1M, 2M, 3R, 3B and 4 on the Palexpo site is subject to the following requirements:

- It must be authorised under the specific regulations of the event in question;
- It must be declared in advance to the police department of the Canton of Geneva, Transport and Environment Group;
- It must be installed in compliance with technical regulation CEI/TR 60825-3 (2008 edition) and with the standard SN EN 60825-1 (2007 edition).

2.15 Hazards due to ionising radiation

Any equipment with ionising radiation must comply with the provisions of the law on radiation protection (LRaP) and the ordinance on radiation protection (ORaP).

In particular, any use of equipment with ionising radiation must be reported to the Federal Office for Public Health (OFSP).

OFSP

Division Radioprotection
CH-3003 Berne

Tél.: +41 (0)58 462 96 14

Fax: +41 (0)58 462 83 83

3. MULTI-STOREY STRUCTURES / COMPLEX CONSTRUCTIONS (bleachers and high structures)

3.1 Approval of plans

At least two months before the exhibition opens, Users must submit a file in duplicate containing the following documents to Palexpo SA's Operations Department for approval:

- Architects' and decorators' plans showing alignments and dimensions;
- Engineering drawings, accompanied by notes of static calculations carried out by a civil engineer guaranteeing adherence to static loading standards;
- The principal hypotheses and the summary of the results must be presented in a separate file containing:
 - a summary of the calculation hypotheses in condensed form;
 - a schematic diagram for all calculations carried out;
 - a summary of the results in the form of graphics and tables showing all the loads and strains;
 - plans showing the positions, in relation to the periphery of the stand, of point loads acting at the bases of pillars.

- Users must construct the load-bearing structures in accordance with plans approved by Palexpo SA's Operations Department. The relevant civil engineering firm is responsible for checking the compliance and the assembly of these structures. The cost of the check is at the expense of the User.

3.2 Loading calculation for structural components

- Levels of floor loading, which depend on the use of the premises, must not exceed the following maxima:

- offices: $p = 200 \text{ kg/m}^2$
- exhibition space: $p = 300 \text{ kg/m}^2$
- conference rooms: $p = 300 \text{ kg/m}^2$
- bars: $p = 300 \text{ kg/m}^2$

P1: average excess loading on the exhibition floor

P2: average permanent loading (load-bearing structures, fittings, furniture etc.), plus average extra mobile loads

P3: average permanent loading (load-bearing structures, ceilings etc.).

The following condition must be met:

$P1 + P2 + P3 = P$ (average uniformly distributed load, as per Article 1.2 Floor loads).

The components of load-bearing structures must be designed for the carrying capacities indicated above.

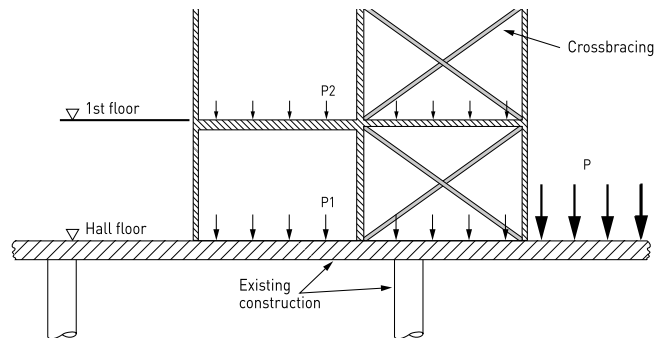

- Horizontal stability must be assured by an appropriate cross-bracing system. A horizontal load exerting a multi-directional force at floor level and equivalent to a minimum of 10% of the live load must be taken into account in the stability calculations;
- Any vertical element inside or on the periphery of a stand must withstand either a horizontal load of 20 kg/m^2 , or a point load of 200 kg applied at its highest point.

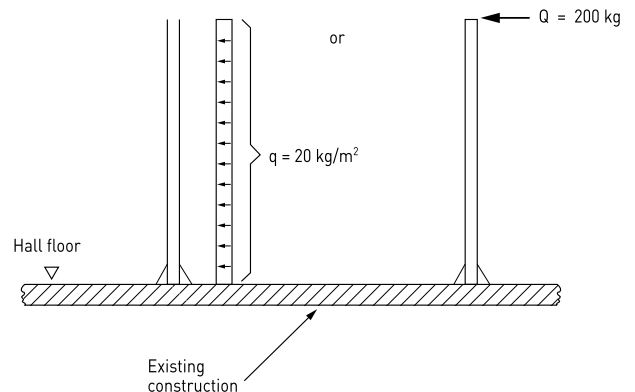

3.3 Permissible local stress on the floor of Halls 4 and 5

The type of flooring in Halls 4 and 5 means that the floor support plates must be calculated for permissible local stress of:

q loc. max. = 6 kg/cm² (for Halls 4 and 5).

3.4 Lifts - Temporary equipment for the transport of people

For all mobile equipment such as lifts or service lifts (whether or not for the transport of people) and escalators:

a) applications must be made to:

**Département de l'aménagement, du logement
et de l'énergie (DALE)**

Police du feu

Rue David-Dufour 5

Case postale 22

1211 Genève 8

Tel.: +41 (0)22 546 66 22

policedufeu@etat.ge.ch

b) installation may only be carried out by a contractor approved by the DALE.

The following SIA standards apply:

- Cable lifts: standard SIA 370/10
- Hydraulic lifts: standard SIA 370/11
- Escalators: standard SIA 370/12

These standards may be obtained from the following address:

Société suisse des Ingénieurs et des Architectes (SIA)

Secrétariat général SIA

Selnaustrasse 16

Case postale

CH - 8027 Zürich

Tel.: +41 (0)44 283 15 15

Fax: +41 (0)44 283 15 16

www.sia.ch

They may also be downloaded from the following website:

<http://www.webnorm.ch/F/Groups/>

3.5 Stairways/Gangways/Platforms

See also Article 2.9, Exits.

Stairways must have a minimum width of 1.20 m and be fitted with 1.00 m high handrails measured at the most dangerous point. As a general rule, stairs shall consist of straight or nearly straight flights, and the slope shall not exceed 35°.

A platform must be installed part of the way up, if the stairways are higher than 3.00m.

Openings leading to a drop must be closed off by safety rails 1.00 m high and bars close enough together to prevent a sphere 12 cm in diameter from passing between them. In addition, the bars should be so designed as to discourage people, children in particular, from climbing up them.

Gangways, platforms and ladders 50 cm or more from the ground must be fitted with handrails and safety rails 1.00 m high.

3.5.1 Spiral staircases

Spiral staircases cannot be used as the only means of escape from stands with an upper storey.

Steps must have a minimum width of 1.50 m.

General terms and conditions of sales and rental services

Index	Page
1. Shop-online.....	32
2. Services available through Shop-online	32
3. Exclusivity	32
3.1 Palexpo SA catering exclusivity	32
3.2 Exclusivity of certain services offered by Palexpo SA.....	32
3.3 Exclusivity contracts.....	32
4. Shop-online orders/contracts	32
5. Orders/contracts outside Shop-online.....	32
6. Order details.....	32
7. Order rescindment/cancellation	32
8. Order deadlines/rates.....	32
9. Online payment	33
10. Online payment security.....	33
11. Payment by invoice.....	33
11.1 Invoicing by Palexpo SA.....	33
11.2 Invoicing by the Organiser.....	33
12. Compliance with terms of payment	33
13. Swiss value-added tax (VAT)	33
14. Personal data/Statistics.....	33
15. Intellectual property in connection with Shop-online	33
16. Liability of Palexpo SA	34
17. User liability	34

1. SHOP-ONLINE

Palexpo SA administers the sale of certain of its services (see Article 2) under the name Shop-online on the Internet domain gponline.ch, accessible at www.gponline.ch.

Use of Shop-online requires Users to first register with Palexpo SA or with the Organiser to obtain a username (hereinafter "login") and password.

2. SERVICES AVAILABLE THROUGH SHOP-ONLINE

The list and nature of services available through Shop-online are determined by Palexpo SA.

Certain services are available only on the basis of an estimate and cannot be ordered through Shop-online.

3. EXCLUSIVITY

3.1 Palexpo SA catering exclusivity

Users must respect catering exclusivity at Palexpo, as set out below:

Commercial catering facilities and Conference Centre

- a) The operation of the fixed catering facilities is to be conducted solely by Palexpo Restaurants, the official Palexpo on-site caterer, for the permanent bars and restaurants as well as for the Conference Centre;
- b) The temporary set-up of restaurants and bars within the exhibition halls or elsewhere on the Palexpo site is to be conducted solely by Palexpo Restaurants.

Catering services in the halls

- c) The preparation and delivery of food and beverages are to be conducted solely by Palexpo Restaurants and its approved partners*.

* You can find the list of Palexpo SA approved catering partners at: <https://palexpo.ch/en/providers>

3.2 Exclusivity of certain services offered by Palexpo SA

The following services are to be ordered exclusively from Palexpo SA:

- a) Connections to the Palexpo networks (electricity, fresh water and waste water, air conditioning, compressed air, telephone, telecommunications, IT, Internet, radio/TV network);
- b) Work related to the buildings: suspending items from the roof structure, darkening of the halls, use of the roof (installing antennae), and so on;
- c) Transport and parking: supply of parking permits (cars, trucks, delivery vehicles) and access to Palexpo (minibuses and limousines);
- d) Ventilation, cooling and/or additional heating of the premises;
- e) Rental of mobile elevating platform for people (nacelle) without driver.

3.3 Exclusivity contracts

Users must respect the exclusivity contracts concluded by Palexpo SA with specific service suppliers and contractors. The following services must be ordered exclusively from such suppliers and service providers:

- a) Automatic banking facilities;
- b) Fixed and mobile advertising areas outside and inside the building, including their content, which may not be removed or concealed;
- c) Handling, loading and unloading on the Palexpo site, as well as rental of the necessary handling equipment;
- d) Study and advice in environmental engineering.

4. SHOP-ONLINE ORDERS/CONTRACTS

The User may prepare an order as a draft ("draft order") and modify it at any time. This draft order will not be deemed final until it has been recognised as such by the User ("confirmed order").

The services offered by Shop-online merely constitute an invitation to submit a quote. This quote is not binding.

A final order ("confirmed order") placed by a client via Shop-online constitutes a firm order placed with Palexpo SA. This order will not become binding until it has been accepted by Palexpo SA. Acceptance is understood to be acknowledgment of the order by a Palexpo SA employee, billing or supply of services, or delivery of the product.

The automatic online order confirmation sent and received as an e-mail message does not constitute acceptance, but is merely intended as a summary of the order.

5. ORDERS/CONTRACTS OUTSIDE SHOP-ONLINE

Orders other than those placed through Shop-online (i.e. by fax, e-mail, post, etc.) and deemed to be incomplete cannot be processed. Palexpo SA shall notify the User by phone or in writing.

The procedure for concluding a contract is identical to that for Shop-online orders.

If the User fills out a paper order form, it must clearly list the following information:

- a) Stand name and number;
- b) Name and address of company responsible for payment. No modification of the billing address will be accepted after receipt of the order form;
- c) Date and signature

6. ORDER DETAILS

By placing an order through Shop-online or by other means, the User:

- a) confirms that the information provided is accurate and true, especially with regard to technical orders;
- b) accepts and agrees to abide by the Terms and Conditions of Palexpo SA as well as the Regulations on order forms.

If necessary, the order must be supplemented by a sketch or plan indicating location(s) of any connection, which should be sent by post or e-mail to Palexpo SA as quickly as possible.

Any omission, error or subsequent modification may result to additional charges, to be borne by the User.

See Article 7 for order cancellation.

7. ORDER RESCINDMENT/CANCELLATION

All Users are entitled to withdraw the order within 7 days of placing it, if:

- a) the services sold do not match their description;
- b) the descriptions contain erroneous information.

Cancellation of orders occurring for any reasons other than the ones listed above will be billed as follows:

In case of cancellation more than 15 days prior to the build-up of the exposition:

- If the service has not been delivered 0 %
- If the service has been delivered 100 %

In case of cancellation less than 15 days prior to the build-up of the exposition:

- If the service has not been delivered 30 %
- If the service has been delivered 100 %

In the case that the cancellation takes place on the 1st day of the build-up of the exposition (or later):

- If the service has not been delivered 50 %
- If the service has been delivered 100 %

For packages a prorata billing will occur in regards to the services that have already been delivered.

For any modifications to the order, please see Article 6.

8. ORDER DEADLINES/RATES

When returning their orders, Users are advised to observe the deadlines listed in Shop-online and/or the order forms.

Beyond these deadlines, Palexpo SA no longer guarantees the availability of materials and manpower necessary to carry out the service.

The rates charged for ordered services may vary based on the following:

- a) Preferential rates may be applied to orders received before the indicated deadline;
- b) Subsequent to this date and before the first day of build-up, orders and order changes are subject to standard rates;

- c) Orders and order changes received after the first day of build-up are subject to a surcharge; in addition, their installation can no longer be guaranteed.

All rates for services shown in Shop-online include VAT, but do not include shipping or packing (see Article 13). Exceptions are listed separately.

Rates are subject to change, due in particular to an increase in VAT rates or the price of materials.

9. ONLINE PAYMENT

For selected events, Users may not only order but also pay for certain services directly via Shop-online.

Payment must be made by credit card: American Express, Visa, Eurocard/MasterCard, Postcard.

10. ONLINE PAYMENT SECURITY

Palexpo SA's Shop-online has a highly effective security system.

Online payments are made in line with the General Terms and Conditions of Palexpo SA's payment system vendor. All information is protected and encrypted prior to transmission to the processing centre. The SSL (Secure Socket Layer) encryption protocol optimises security when transmitting sensitive data linked to methods of payment.

Palexpo SA has no access to any confidential information related to the method of payment. Users are therefore prompted to re-enter their payment details every time they place an order.

Only the Palexpo SA vendor has access to confidential information (card number, expiry date), and this information is not available to any third party.

No more than one payment shall be authorised for each order.

Regardless of the payment method, payment must be made in the name of the User who ordered the services, unless otherwise agreed by Palexpo SA.

The User's credit card shall be charged at the time of the order. The order shall be deemed paid upon acceptance of the payment by the credit card issuer. If the transaction is denied, the order shall be cancelled.

11. PAYMENT BY INVOICE

Services ordered from Palexpo SA without online payment shall be invoiced either by Palexpo SA or by the Organiser.

11.1 Invoicing by Palexpo SA

The invoices sent out by Palexpo SA are due and payable in full, net, upon receipt.

The invoicing system is made up of one or more partial invoices (instalments) prepared by Palexpo SA before, during, and after the event, and one final summary invoice. Each partial invoice lists the provisional status of the orders. The final invoice corresponds to the actual status of the services rendered and concludes the invoicing process.

Payments must be made in the currency of the invoice by:

- bank transfer to the Palexpo SA bank account(s) mentioned on the invoice;
- credit card: American Express, Visa, Eurocard/MasterCard, Postcard.

Please indicate the card number, expiry date, security code, cardholder name and the amount to be debited.

11.2 Invoicing by the Organiser

Invoices issued by the Organiser shall be subject to the Organiser's invoicing system.

12. COMPLIANCE WITH TERMS OF PAYMENT

Palexpo SA is entitled to suspend, without notice, the performance of any of its obligations in the event of non-payment by the due date. Unless payment is received by the due date, the ordered services shall not be provided or the removal of goods after the end of the event shall not be permitted.

Services ordered on-site must be paid for immediately.

Payment reminders will be billed at CHF 20.00 per reminder. In addition, an interest penalty of 5% per annum shall be applied without prior notice.

In the event of non-payment of an amount due by a subcontractor (stand builder, suppliers, and so on) appointed by the standholder, the latter shall pay the expenses related to the services ordered on its behalf and provided by Palexpo SA and/or its partners within the context of the event.

If standholders wish to countersign every order placed by their subcontractors, they must notify their subcontractors and Palexpo SA accordingly. In this case, no orders placed by any of the standholder's subcontractors shall be carried out by Palexpo SA staff if the standholder has not signed off on them.

13. SWISS VALUE-ADDED TAX (VAT)

The services provided by Palexpo SA to its clients are subject to VAT, subject to unless an exemption is granted by virtue of Articles 143 to 150 of the ordinance of 27 November 2009 governing VAT.

Services provided to a User domiciled outside Switzerland are also subject to VAT, the place of execution of the service (Switzerland) being decisive by virtue of Article 8(2)(B) of the law of 12 June 2009 governing VAT. However, under certain conditions, Users based outside Switzerland may request a VAT refund.

Any change in the VAT rate may have immediate repercussions on our prices.

14. PERSONAL DATA/STATISTICS

Palexpo SA undertakes not to disclose to any third party the information provided by Users on Shop-online, except to partners duly approved by Palexpo SA. This information is confidential and shall only be used by Palexpo SA employees to process orders, consolidate and personalise communication (especially by informative letters or e-mails) and in efforts to customise the site, based on the preferences expressed by Users.

In other words, Palexpo SA does not sell, market or rent to third parties any of the information pertaining to Users. Palexpo SA reserves the right to do so in the future, in direct relation to the performance of contracts concluded by Palexpo SA with Users.

If data of a personal nature is to be transferred to or used by third parties, Palexpo SA shall notify Users in advance to allow them to exercise their right of opposition.

Palexpo SA may also provide trusted third parties with consolidated statistics related to Users and to information on Shop-online. However, such statistics shall under no circumstances contain any personal data.

Pursuant to the federal law of 19 June 1992 on data protection (LPD - RS 235.1), Users are entitled to access, modify, rectify and delete personal data concerning them by sending a request to Palexpo SA (indicating their e-mail address, last and first names and postal address). They can do so by visiting the Palexpo SA website at www.palexpo.ch, under Ask your question, or by posting their request to the following address:

Palexpo SA
Route François-Peyrot 30
P.O. Box 112
CH - 1218 Le Grand-Saconnex

15. INTELLECTUAL PROPERTY IN CONNECTION WITH SHOP-ONLINE

All texts, comments, works, illustrations and images, whether visual or sound, reproduced on the websites of the Internet domain gponline.ch are protected by copyright, trademark rights, patent rights and image rights for the whole world.

They are wholly owned by Palexpo SA.

As such and pursuant to the provisions set forth by law, only private use is authorised, subject to differing or more restrictive provisions stemming from intellectual property legislation.

Framing or deep linking must not be used to establish a hypertext link to the websites of the Internet domain gponline.ch without the prior consent of Palexpo SA. Any link, even if tacitly authorised, must be removed immediately if requested by Palexpo SA.

Unless authorised previously by Palexpo SA, any other use shall be deemed unlawful and subject to sanctions pursuant to intellectual property legislation.

The reproduction in whole or in part of Palexpo SA's services catalogue is strictly prohibited.

16. LIABILITY OF PALEXPO SA

The description, information, comments, photos (if any) or other illustrations, whether visual or sound, mentioned for each service on the websites of the Internet domain gponline.ch are those provided by Palexpo SA to its clients. They are provided for information purposes only and are not binding.

Accordingly, Palexpo SA shall not be held liable for any errors these may contain. Palexpo SA shall make its best efforts to correct any errors or omissions as soon as possible after notification by Users.

In any event, the liability of Palexpo SA shall be limited to the amount of the order and shall not be assumed for simple errors or omissions that may have subsisted despite the precautions it has taken in presenting its services.

Palexpo SA shall not be held liable for any loss or damage, whether material, immaterial or corporal, which may result from malfunction or inappropriate use of Shop-online.

Palexpo SA shall not be held liable for the non-execution of the order in the event of insufficient inventory or unavailable services, force majeure or for any unforeseeable political, economic or public health events.

Similarly, Palexpo SA shall not be held liable for any inconvenience or damage related to the use of the Internet such as service interruption, the presence of computer viruses, exterior intrusions or, more generally, for any other events deemed to be force majeure by the courts.

17. USER LIABILITY

Users who have received a login and password shall be solely liable, both legally and financially, to Palexpo SA for using Shop-online on their own behalf and on behalf of third parties appointed by them.

Any fraudulent use of Shop-online or any use in violation of these Terms and Conditions by the User or by any third party appointed by the User may result in the permanent denial of access to Palexpo SA's Shop-online.

Telematics

Index	Page
1. General conditions for internet access	36
1.1 Purpose	36
1.2 WiFi	36
1.3 Wired Internet	37
1.4 Access to Palexpo SA's Internet service.....	37
1.5 Indoor GPS	37
1.6 Professional advice and support	37
1.7 Security	37
1.8 Cookies	38
1.9 Users' commitments and responsibilities.....	38
1.10 Palexpo SA's commitments and responsibilities	38
1.11 Suspension/Withdrawal	39
1.12 Non-personal data and personal information	39
1.13 Force majeure.....	39
2. Use of walkie-talkies	39

1. GENERAL CONDITIONS FOR INTERNET ACCESS

1.1 Purpose

The purpose of this document is to define the conditions for use of wireless Internet access services (hereinafter "WiFi") and cabled Internet access services (hereinafter "wired Internet") offered by Palexpo SA on its site.

1.2 WiFi

1.2.1 Goal

The Palexpo WiFi service allows Users with a compatible PDA or laptop computer to connect wirelessly to the Internet within the area covered by the Palexpo network. The WiFi service provides basic Internet access functions. It enables Users to connect to the Internet, particularly for the purposes of communication using electronic message systems.

However, our service does not offer other features such as mail boxes, nor web page hosting.

Palexpo does not guarantee access to other systems such as company networks. Users should therefore check the technical options for connecting to their company's private network on their own.

1.2.2 Accessibility

The WiFi service is accessible from any devices equipped with a Wireless LAN interface corresponding to the standard IEEE 802.11 a/g/n/ac/ax.

WiFi in the exhibition halls is only available on the frequency band 5 GHz. Upon written request, the frequency band 2.4 GHz can be activated.

WiFi at the main entrance (indoor and outdoor area), in the congress centre, on the two esplanades and in the Villa Sarasin is available on two frequency bands (2.4 GHz and 5 GHz). WiFi is free to access in these two areas.

Only the frequency band of 5 GHz is guaranteed.

1.2.3 Recommended configuration for computer terminals

Palexpo SA recommends the following configurations:

- Windows 10, version 20H2 (E) or later;
- MacOS 10.15 (Catalina) or later;
- Android 10 Queen Cake;
- WiFi Dual Band pre-equipped or equipped with a WiFi Dual Band USB adapter compliant with the IEEE 802.11 a/b/g/n/ac/ax standard.

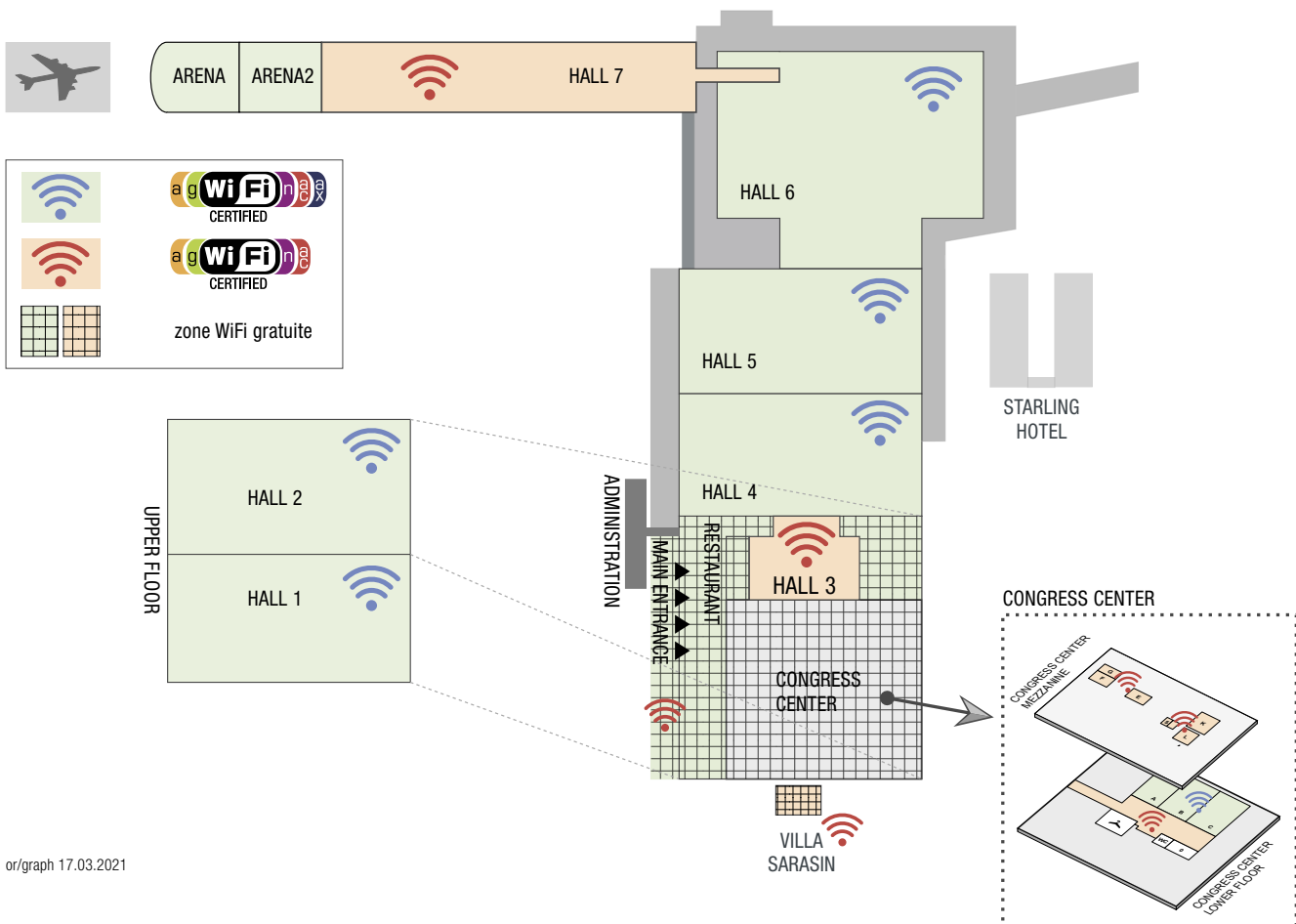

or/graph 17.03.2021

1.2.4 Restriction

Palexpo SA uses and offers **exclusively** 802.11 a/g/n/ac/ax WiFi technology on its site. In order to maintain a high-performance WiFi service, Palexpo SA has published rules to control the quality and offer a quality experience to Users.

Our standard services can be ordered through the event Shop online. Our experts are at your disposal for any technical information or special requests. They can be reached at the following email address: telematics@palexpo.ch.

Therefor, no third parties will be permitted to set up equipment operating in the frequency band of 2.4 GHz and 5 GHz within Palexpo's current buildings or in temporary structures on its property. The installation of any WiFi equipment not provided by Palexpo SA shall not be permitted.

Transmitting on the frequencies 2.4 GHz and 5 GHz is exclusively reserved for Palexpo WiFi infrastructure. Our standard services can be ordered through the event Shop online. Our experts are at your disposal for any technical information or special requests. They can be reached at the following email address: telematics@palexpo.ch.

1.2.5 Special authorisation

Palexpo SA offers you a technical solution to achieve all your objectives. By default, no derogation from these Regulations will be granted.

However, for very specific needs related to the presentation of products using WiFi technology as their main basic function and upon express request to the Palexpo SA Telematics Service, exceptional authorisation may be granted to the User.

Any request to install WiFi equipment such as a remote control, an ad hoc link, microphones, AV control, etc. will not be accepted.

Please submit your request for special authorisation by e-mail to the Palexpo SA's Telematics Service at address telematics@palexpo.ch. The following information must be provided to us:

- The event, the name and number of your stand;
- Contact information for a person responsible for the equipment;
- Make and model of the system transmitting and receiving WiFi;
- SSID of the equipment in question (broadcasting not permitted);
- Reason for your request for special authorisation;**
- A plan of your stand, showing the positioning of the equipment;
- Transmission strength (a maximum of 10 mW);
- Configuration in automatic mode with maximum 20 MHz channel.**

All requests for special authorisation must be submitted at least **2 weeks** before the event begins.

1.2.6 Non-compliance with these regulations

No transmitter in the 2.4 GHz and 5 GHz frequency bands may be installed by a third party within the Palexpo buildings or in temporary infrastructures built on the site.

Any WiFi installation not provided by Palexpo SA will be considered as a rogue that may cause disturbances and security problems. Any User who may attempt to connect to it will be automatically disassociated by the Palexpo SA Telematics Service.

Users or their agents who violate these Regulations may be subject to financial prosecution to the extent of the damage.

1.3 Wired Internet

1.3.1 Goal

The wired Internet service allows any User with a terminal equipped with an RJ45 Ethernet interface to connect to the Internet via their browser. The service includes basic Internet access functions.

This service does not include the provision of email or hosting.

Palexpo does not guarantee access to other systems such as company networks. Users should therefore check for himself the technical options for connecting to their private network or that of his company.

1.3.2 Recommended configuration for computer terminals

Palexpo SA recommends the following configurations:

- Windows 10, version 20H2 (E) or later;
- MacOS 10.15 (Catalina) or later;
- Android 10 Queen Cake;
- Pre-equipped with a Giga Ethernet RJ45 card or using a Giga Ethernet RJ45/USB adapter.

1.4 Access to Palexpo SA's Internet service

1.4.1 Access to the WiFi service

In principle, WiFi service is available around the clock at Palexpo. However, it is subject to the opening hours of the site, in accordance with the limits and conditions of the WiFi service purchased by the User from Shop-online, the Exhibitor Relations Office, or by credit card online. Users must identify themselves in order to use the service.

1.4.2 Access to the wired Internet service

The wired Internet service, to be ordered in advance, is available 24 hours before the opening of the event.

In principle available 24 hours a day, access to the connection depends on the opening hours of the spaces rented by the User.

1.5 Indoor GPS

Palexpo SA offers an indoor GPS repeater service. This service is based on an temporary infrastructure of antennas, splitter, coaxial cables and repeaters.

The User who wishes to obtain this service must make a prior request to Palexpo SA with a minimum period of three months before the date of use of the service. After this period, the service is no longer guaranteed.

Each repeater controlled by the User covers a surface area of approximately 900 m².

The two frequencies used by the GPS systems, frequencies are L1 (1 575.42 MHz) and L2 (1 227.60 MHz) are protected by the Swiss Telecommunications Law, which is also true for the frequencies of other systems such as Glonass, Galileo etc.

GPS simulators are strictly prohibited indoors and outdoors and are governed by Swiss law. The Federal Office of Communications (OFCOM) can provide you with information on this subject.

<https://www.bakom.admin.ch/bakom/en/homepage/equipments-and-installations/in-general.html>

1.6 Professional advice and support

Networking advisors are available to help Users with their projects. The support service is available during the opening hours of the event:

- By phone at +41 (0)22 761 12 34;
- By email to telematics@palexpo.ch.

1.7 Security

In principle, communications carried out using these services have the same level of security as standard Internet communications. If Users wish to reinforce the security level, they may install security software such as a firewall or VPN (Virtual Private Network) themselves. However, Users must ensure that such security software does not prevent access to services.

As this security software is third party software, Palexpo does not take responsibility for its functioning. Absolute protection against intrusion or eavesdropping cannot be guaranteed. Palexpo SA shall not be held liable for any such occurrences.

Users are reminded that the Internet is not a secure network. In view of this, it is up to Users to take all the necessary measures to protect their own data and/or software, especially against infection by any viruses on the Internet or intrusion by a third party into their computer's system (desktop PC and laptop PC) for any purpose, and to back up their PCs before and after using the service.

Users also acknowledge that they are fully aware that there are flaws in the reliability of the Internet, particularly in terms of the insecure nature of data transfer and the fact that performance cannot be guaranteed as regards the volume and speed of data transfer.

Palexpo SA shall not be held liable for anything that goes wrong during data transfer.

Users acknowledge that they are fully aware having been informed that the integrity, authentication and confidentiality of any kind of information, files or data transferred over the Internet cannot be guaranteed on this network. Therefore, Users should not use the Internet to transfer any messages that must be kept absolutely confidential. **Palexpo SA shall not be held liable for any loss or corruption of information and/or data stemming from using our services or for any impact that the use of our services may have on Users' equipment and/or software.**

1.8 Cookies

It may happen that files known as cookies are stored on Users' computers when they use our Internet services. These files facilitate browsing for Users and enable Palexpo SA to provide better service. Cookies memorise Users' data so that Users do not have to re-enter them during subsequent visits. Users have the option of disabling them or deleting them from their hard drives.

However, Users should be aware that certain services offered on the Internet will not be accessible – or will only be partly accessible – if they do not enable cookies. If Users wish to be informed (with a warning message) every time a cookie is installed or prevent cookies from being saved to their computers, they must configure their Internet browsers accordingly.

1.9 Users' commitments and responsibilities

1.9.1 General principles

The use of Palexpo's WiFi or wired Internet services is subject to the User's compliance with these Regulations, it being understood that any use of one or other of the services requires irrefutable approval of the following principles by the User, without a signature being necessary and notwithstanding compliance with the applicable laws and regulations.

The provisions below apply to all Users of services, regardless of whether access is free or paid or whether payment was made to Palexpo SA, a partner or a third party.

1.9.2 Access codes / logins

Within the framework of the services to Users: WiFi Standard and Premium, these services are multi-users and therefore the responsibility is borne by the Users to transmit the services access code to the appropriate person.

Within the framework of the single-users services sold directly on the PALEXPO WIFI portal, the services offered are intended for one terminal, consequently the logins delivered by the network are personal and confidential. By using these identifiers, the User has a personalised and exclusive access to the services. He is not allowed to transfer identifiers to third parties.

Any use of the User's identifiers is made under his entire responsibility, and Palexpo SA declines all responsibility in this regard.

1.9.3 Service use

Users are solely responsible for all direct or indirect, material or immaterial damage caused to third parties and/or to Palexpo SA as a result of their use of WiFi or wired Internet services. Users are solely responsible for the use of their login or password. Any use of these services (e.g. data transfer) made via the User's login and password user is assumed to have been initiated by the User.

Users agree not to use the services for illicit, prohibited or illegal purposes.

Use of the services by the User is considered as confirmation that the User accepts Palexpo SA's regulations on the matter in their entirety, without any option for modification. Any communications from Users with the intent of modifying the applicability of these regulations or their content shall be void, regardless of whether Palexpo SA received/responded to them.

1.9.4 Applicable legislation

In this regard, Users must comply with the applicable legislation on the following matters (this list is not exhaustive):

- Respect for the privacy of all people;
- Copyright and intellectual and industrial property, especially in relation to multimedia creations, software, texts, press articles, photographs, sounds, pictures of all kinds, trade marks and brands, patents, drawings and models, it being noted that any mention relating to the existence of rights on these elements and/or data and/or files may not be deleted and that any reproduction of a work or one of these elements and/or files and/or data without the consent of the holder of the rights constitutes counterfeiting;
- Automatic processing of personal data, particularly the federal law of 19 June 1992 on data protection (LPD - RS 235.1);
- Respect for the rules of public order with regard to the content of information that may be made available on the Internet and that undermines the integrity or feelings of the network users by accessing provocative messages, pictures or texts;
- confidentiality of correspondence and the ban on intercepting communications made by means of telecommunications.

1.9.5 Other commitments by the User

Within the context of their use of WiFi or wired Internet services, Users also undertake not to:

- Mine or collect information about third parties without their consent;
- Defame, disseminate, harass, stalk or threaten anyone, or violate others' rights;
- Create a false identity;
- Attempt to obtain unauthorised access to a service and/or piece of information and/or file;
- Spread or allow downloading of any elements containing software or other items protected by intellectual property rights, unless the Users themselves hold those rights or have received the necessary authorisation;
- Send undesirable messages or engage in spamming;
- Send messages and/or electronic messages with content that is illicit, improper, insulting, defamatory or indecent or undermines any rights, especially human rights and the protection of minors;
- Transmit viruses, Trojan horses, logic bombs or any other harmful or destructive program to third parties and/or other Users;
- Attempt to acquire unauthorised access to an automated data processing system or to remain there;
- Disrupt the services and/or content and/or data they access;
- Send chain letters or offer snowball or pyramid sales;
- Send advertising, promotional messages or any other form of unwanted solicitation to other Users.

It is up to Users to check that they have the necessary hardware, software and browsers to use the service; Palexpo SA may not, under any circumstances, be held liable for responsible for the aforementioned equipment, which was chosen by Users. Users are also responsible for the security and protection of their own equipment.

If Users wish to restrict access to certain sites, servers or data, it is up to them to acquire the relevant products from Internet security providers.

1.10 Palexpo SA's commitments and responsibilities

Palexpo SA does everything in its power to provide the services mentioned above.

Services are made available as described in Article 1.4 above, excepting interruptions for technical reasons, which Palexpo SA shall attempt to remedy with all reasonable means and in a timely manner.

The wired and WIFI internet infrastructure is based on redundant infrastructure and operator access. DDoS services also provide a guarantee of Internet access availability.

Under no circumstances shall Palexpo SA be held liable for any loss exceeding the value of the service ordered by the User. The calculation of the loss in the event of a service failure shall be calculated on a pro rata basis according to the time of unavailability of the concerned service.

1.10.1 Content

Palexpo SA shall not be held liable for any content accessible over the Internet and any damage resulting from its use, unless this damage was caused deliberately by Palexpo SA.

Since private correspondence must be kept confidential, Palexpo has no control over the content or characteristics of data received or transmitted by the Users on the network and/or on the Internet. Nevertheless, to ensure good management of the access system for Palexpo's Internet services, Palexpo SA reserves the right to delete any message or prevent any activity by Users that is likely to disrupt the operation of the network or Internet, or that does not comply with the rules of operation, the applicable legal standards, ethical standards or ethical practice.

Exceptions to this rule of confidentiality may be made within the limits allowed by law at the request of the public and/or legal authorities.

1.10.2 Liability

Palexpo SA shall not be held liable for the use of data and information that Users introduce on the Internet network.

Palexpo SA shall not be held liable for extreme, fraudulent or excessive use of the Internet by Users, especially intentional or unintentional blockage of e-mail servers or e-mail addresses by indiscriminate direct mail advertising (spamming, bulk e-mail, junk e-mail or mail bombing), or blockage of its network, or the dissemination of teasing or trolling messages that generate an excessive number of answers and are thus able to disturb the availability of the aforementioned servers or network.

In particular, Palexpo SA shall not be held liable in the event of:

- Use of material or equipment not recommended by Palexpo SA;
- Incorrect installation and/or incorrect configuration and/or malfunction of the User's terminal;
- Incorrect use of WiFi or wired Internet services by the User;
- Users' non-fulfilment of their obligations;
- Inability to access a company's private virtual network (VPN) over the Internet;
- Slowness, disruptions or interruptions of remote services, such as streaming systems, cloud, web server, mail server, application server, etc.;
- Disclosure, loss or theft of the associated access codes or logins and, more generally, in the event of use of the said service by an unauthorised person, where this is not resulting from a fault of Palexpo SA;
- Disruption and/or total or partial unavailability and/or interruption of all or part of the services offered on the networks operated by third-party operators;
- Inability of the User to demonstrate to the Palexpo SA network specialist that the service is faulty;
- Inability to reproduce the problem encountered in the presence of the Palexpo SA network specialist.

Palexpo SA shall play no part in any disputes between Users and third parties.

More generally, Palexpo SA may not, under any circumstances, be called upon to remedy any direct and/or indirect harm suffered as a result of Users' use of services. Users hereby acknowledge that Palexpo SA cannot be held liable for the content Users access, and that access to content and service is not guaranteed and may be suspended without prior warning.

1.11 Suspension/Withdrawal

Palexpo reserves the right to suspend and/or withdraw WiFi or wired Internet access services if the User fails to meet one of its obligations, especially in the event of piracy or attempted illicit use of information circulating on the network where this act or attempt originates from the User's account. Palexpo SA may not be held liable in this event, and the User may not claim any compensation or remedy.

Palexpo reserves the right to provisionally or permanently suspend use of WiFi or wired Internet services if asked to do so by a third party and/or competent authority. Palexpo SA may not be held liable in this event, and the User may not claim any compensation or remedy.

1.12 Non-personal data and personal information

Palexpo SA may save and process some data like the type of browser used or the location from which the User connects. These data shall be saved and processed by Palexpo SA, either acting directly or via a third party. Under no circumstances do these data enable a link to be made with the User, and Palexpo SA shall use them exclusively to obtain information enabling it to offer efficient internet access or develop other related commercial services.

Palexpo SA may transfer some or all of these non-personal data to third parties, primarily in order to inform the owners and operators of web pages linked by access-related services about the number of Users accessing them. Under no circumstances can these data be linked to the User.

Within the framework of the use of WiFi or SDSL services, for its own ends Palexpo SA gathers data relating to the traffic generated by the User and then stores, retains and processes this information on the User's communications. In principle, these communications data do not permit the User to be identified. Palexpo SA does not process these data with a view to enabling it to identify the User. However, there is no ruling out the possibility of some cross-referencing between information ultimately enabling a User to be identified on the basis of the data in question. By using the access services provided, the User consents to the collection of data and the processing thereof as set out above.

In the event that the data referred to in the preceding paragraphs intrinsically include personal information and if future technological advances permit these personal data to be identified and processed, Palexpo SA shall strictly comply with the mandatory data protection standards applicable at the time. In this regard, by using access services, the User consents to Palexpo SA's future processing of these personal data, either directly or via a third party, in line with the objective set out in the present document.

More generally, Palexpo SA shall be entitled, if need be via a third party and in the context of marketing follow-up associated with access services, to collect personal data such as surnames, first names, telephone numbers and e-mail addresses. These data shall be collected directly from each User, who shall have the choice of divulging this information or not. Should the User provide all or some of these personal data, they may be transferred, in full or in part, to third parties organising the event in which the User participated, for marketing purposes accepted by the User.

To the extent required by the application of mandatory standards, Users shall be entitled to exercise their rights regarding any personal data concerning them, first and foremost the right to access and the right to rectify incorrect data stored by Palexpo SA.

Independently of the content of the provisions of the present document, Palexpo SA shall comply with any decision (judgement, administrative ruling) that may be reached by any competent authority and is binding on Palexpo SA, without suffering any form of reproach whatsoever made against it by the User.

1.13 Force majeure

Palexpo SA shall not be held liable for non-fulfilment or partial fulfilment of its obligations if this non-fulfilment or partial fulfilment results from a situation beyond its control or a case of force majeure.

2. USE OF WALKIE-TALKIES

Anyone providing a telecommunications service must notify the Federal Office of Communications (OFCAM) of this. The Office registers telecommunications service providers who have notified and assigns the radio frequencies. See Telecommunications Act and its regulations.

All requests must be done in advance in order to ensure that the requested frequencies are available and approved.

<https://www.admin.ch/opc/en/classified-compilation/19970160/index.html>

For rental of walkie-talkies or compliance of your own devices to the norms, Palexpo SA can put you in contact with the approved partner SECRA SA, a specialist in radio communication at events.

info@secra.ch

<https://www.secra.ch/prestations/>

Catering

Index

Page

1. Commercial catering facilities, Conference Centre and Villa Sarasin 41
2. Catering services in the halls..... 41

1. COMMERCIAL CATERING FACILITIES, CONFERENCE CENTRE AND VILLA SARASIN

Users must respect catering exclusivity at Palexpo, as below:

Commercial catering facilities and Conference Centre

- a) The operation of the fixed catering facilities is to be conducted solely by Palexpo Restaurants, the official Palexpo on-site caterer, for the permanent bars and restaurants as well as for the Conference Centre;
- b) The temporary set-up of restaurants and bars within the exhibition halls or elsewhere on the Palexpo site is to be conducted solely by Palexpo Restaurants.

Palexpo Restaurants

Route François-Peyrot 30
CH-1218 Le Grand-Saconnex / Geneva

Tel.: +41 (0)22 761 15 00

Fax: +41 (0)22 798 01 43

restaurants@palexpo.ch

<http://www.palexpo.ch/en/palexpo-restaurants-1>

The restaurants, bars and other food and beverage services have been designed with maximum variety and flexibility in mind. The following facilities operated by the official caterer Palexpo Restaurants are available:

Halls 1 to 7

- Le [.]Central (*), located in the entrance hall / seating capacity: 200 diners / self-service or table service depending on the event taking place at Palexpo / open year-round;
- Le Poivrier (*), located in the entrance hall / seating capacity: 100 diners / French restaurant with table service / only open for certain events;
- Three multi-purpose rooms, V, W and X, located in the entrance hall / total seating capacity: 900 diners / open based on the requirements of each event;
- Hall 3 and room P (*);
- Two snack bars distributed across the halls, plus a lounge bar / open based on the requirements of each event;
- Le Panoramique, a restaurant located over 6 m above Hall 7. It can be accessed via a staircase or a lift. There is a walkway linking it directly to the VIP area of the Geneva Arena auditorium. / seating capacity: 200 diners / open based on the requirements of each event, or upon request.

(* Le [.]Central and Room P can be connected giving a greater seating capacity.

Conference Centre

- All the conference rooms can be also be used for receptions or banquets, capable of accommodating up to 1,500 people.

Villa Sarasin

Magnificent four-storey 19th century mansion

On the lower ground floor, a restaurant / seating capacity: 100 diners / open based on the requirements of each event, or upon request;

- On the ground floor, five interlinked rooms plus an entrance hall, allowing meals to be organised for up to 180 diners / open upon request;
- On the top floor, a beautiful attic room with a bar and lounge area / open upon request;
- Capacity of Villa Sarasin: between 50 and 300 guests, depending on the event (e.g. reception, private party, wedding).

2. CATERING SERVICES IN THE HALLS

With regard to the catering services in the halls, namely the preparation and delivery of food and beverages, Palexpo SA has appointed several catering partners in addition to Palexpo Restaurants.

For a list of Palexpo SA's foodservice partners, please visit the Palexpo site and click on Organiser and exhibitor services – List of service companies: <https://palexpo.ch/en/providers>

"Barista" services must be provided exclusively by Palexpo Restaurants.

Palexpo Restaurants and its partners will be happy to help you, whatever your requirements for mobile foodservices may be: a short coffee break, a reception on a stand or a gourmet banquet for several thousand guests.

Freight handling, Hire of lifting devices, Transport, Customs

Index	Page
1. Exclusive on-site handling agent	43
2. Hire of lifting devices (without driver)	43
2.1 Preamble.....	43
2.2 Hires.....	43
2.3 Property, liability and insurance.....	43
2.4 Fuel and maintenance.....	43
2.5 Restrictions.....	43
3. Freight forwarder	43
4. Transport of goods	43
4.1 Special regulations for trucks.....	43
4.2 Arrival and departure of goods.....	43
4.3 Traffic within the buildings.....	44
5. Customs	44
5.1 Palexpo's Customs Office.....	44
5.2 Surety for Swiss import duties/ATA document.....	44
5.3 Goods admitted for temporary importation.....	45
5.4 Duty-free goods.....	45
5.5 Goods subject to taxes.....	45
5.6 Other import restrictions.....	45
5.7 Goods of animal origin.....	45
5.8 Plant protection.....	45
5.9 Items made of precious metals.....	45

1. EXCLUSIVE ON-SITE HANDLING AGENT

All handling activities and use of forklift trucks and cranes on the Palexpo site must be conducted via ExpoLog Geneva SA, Palexpo's exclusive partner.

This includes:

- the loading and unloading of goods using handling equipment;
- plant hire and/or loan of forklift trucks and cranes; It is prohibited to work within the Palexpo venue with one's own handling engines and vehicles;
- the storage of goods.

Please see the documentation regarding ExpoLog Geneva SA (Appendix 1).

New regulation regarding lifting equipment rental and provision since 1st July 2019: please see Regulations for construction [article 2.4.6](#).

2. HIRE OF LIFTING DEVICES (WITHOUT DRIVER)

2.1 Preamble

These regulations apply to any Users hiring lifting devices from Palexpo SA. The receipt and/or use of the hired lifting device shall constitute acceptance of these regulations.

Palexpo SA points out here that, from a practical point of view, using a lifting device requires perfect technical knowledge and solid working experience. Should Users lack either of these, they must immediately renounce hiring and/or using the lifting device and any of its accessories. Failure to do so shall expose Users to considerable risks that may adversely and seriously affect the physical integrity of persons and/or material goods, including those of the Users themselves and/or any third parties.

2.2 Hires

A hire is valid once the quote is signed by the User.

A detailed inventory, with photo(s) if necessary, will take place upon receipt of the lifting device by the User and when it is handed over at the end of the hire period. Users must carefully examine the lifting device and immediately report in the detailed inventory any possible defects that they find when receiving the device.

Unless otherwise instructed by Palexpo SA, lifting devices must be returned to the same place where the Users first received them.

Lifting devices must be returned clean, complete and in perfect working order by Users.

The hire price includes the provision of the lifting device, excluding a driver/operator (this service can be ordered separately). A deposit of 30% of the hire price is payable by the User upon signature of the quote.

When Users return lifting devices, they undertake to inform Palexpo SA immediately of any damage the device may have suffered. If the lifting device is dirty, deteriorated and/or no longer in perfect working order, it will be repaired and/or cleaned at the User's expense.

2.3 Property, liability and insurance

Hiring a lifting device excludes any acquisition of ownership (and any other real right) by Users regarding the hired device, including accessories, for which Palexpo SA retains exclusive rights at all times. Users are not entitled to make any technical modifications to the lifting device.

Users undertake to be the sole users of the lifting device and its accessories and to not allow any third party to use them. In any case, Users are also liable for any actions by other users during the hire period as if they were their own.

It is the responsibility of the Users hiring the lifting device to carry driving licences (for the lifting device in question) valid in Switzerland with them. Users must provide a copy of their driving licences upon request from Palexpo SA.

Users must move, manoeuvre and, in general, use the lifting device and its accessories with care, and must not have consumed any alcohol and/or narcotics (including any substance impairing the faculties required for the use of the lifting device) before and/or during the use of the lifting device.

Users are liable for any damage caused to the lifting device (and its accessories), to the equipment of Palexpo SA and/or to third parties. In the event of damage, Users must inform Palexpo SA in writing without delay.

Users must be covered by all appropriate insurances, in particular civil liability insurance covering any third party (whether Palexpo SA and/or any third party) for damage that the user could cause and/or for which he would be responsible.

Users shall be liable for the consequences in the event of loss and/or theft of the lifting device and/or any of its accessories.

2.4 Fuel and maintenance

Palexpo SA is responsible for filling the tanks of lifting devices with combustion engines.

Users are responsible for charging electric lifting devices in the evening.

2.5 Restrictions

It is forbidden to drive lifting devices on the Palexpo site during the opening hours of the exhibition.

It is also forbidden to enter the interior of the Palexpo framework with a lifting device, to hook elements to it or to move/handle equipment from the beams of the framework.

It is also forbidden to lift loads with lifting devices. These are intended only for the purpose of raising people (within the applicable weight limit).

Users are not allowed to sublet lifting devices to third parties or to use them on behalf of another User or to dispose of them in any other way.

3. FREIGHT FORWARDER

ExpoLog Geneva SA also supplies the following services: transport and customs clearing.

However, Users are free to choose a freight forwarder for transport to and from Palexpo and/or for customs clearance.

4. TRANSPORT OF GOODS

4.1 Special regulations for trucks

(no traffic at night, on Sundays and on public holidays)

Road transport is subject to the provisions of the ordinance of 13 November 1962 on road traffic regulations (OCR - RS 741.11).

Truck drivers must comply with the regulation prohibiting driving of heavy vehicles at night (between 10.00 p.m. and 5.00 a.m.) and all day on Sundays and public holidays.

This prohibition concerns heavy motor vehicles of which the gross weight exceeds 3.5 t, as well as articulated vehicles and road trains of which the overall weight exceeds 5 t.

Vehicles used for passenger transport are exempt from this prohibition

4.2 Arrival and departure of goods

The Palexpo goods area is reserved exclusively for loading and unloading. Vehicles must leave the area once these operations have been completed.

Unless otherwise stated by Palexpo SA, all goods must enter and leave Palexpo through the gate nearest the relevant stand.

Only the lifting and handling equipment supplied by the exclusive on-site handling agent may be used on the Palexpo site. This concerns the following plant in particular: forklift trucks and cranes.

Palexpo SA reserves the right to oblige organizers to use a digital traffic management system for assembly and dismantling. This system is operated by Expolog Geneva SA.

4.2.1 Halls 1, 2, 4, 5 and 6

Trucks and cars can access the exhibition halls at ground level.

4.2.2 Hall 7

Trucks and cars can access the exhibition hall at ground level. Hall 7 has a perimeter road that passes around the hall and the Geneva Arena auditorium and ends at the Carrefour des Traz crossroads.

The service area behind the hall, on the airport side, leads from the second half of the building to an exit road that is exclusively reserved for vehicle traffic. This road must not be used for loading, unloading or parking.

Stopping, loading and unloading may be conducted in the area between the Carrefour des Traz crossroads and the building during the assembly and dismantling of an exhibition, subject to authorisation. However, they are prohibited while the event is open to the public.

Palexpo SA reserves the right to oblige organizers to use a digital traffic management system for assembly and dismantling. This system is operated by Expolog Geneva SA.

4.3 Traffic within the buildings

4.3.1 Exhibition halls

The speed limit in the building is 10 km/h.

Truck drivers are requested to keep to the routes specified by Palexpo SA's Operations Department, and to comply with the instructions it issues.

The emergency exits and service doors must always be kept clear, both inside and outside the buildings.

No vehicle is permitted to load or unload equipment or park in front of emergency exits, for any reason whatsoever.

Use of pallet transporters is not allowed on carpeted aisles and wooden floors. Drivers of forklift trucks (loaded or light) must ensure during operation that the floor is not damaged by the forks or by the goods being carried.

4.3.2 Entrance hall, Hall 3, Conference Centre, lobby and mezzanine

The following vehicles are allowed:

- vehicles without engines, with plastic wheels (nylon);
- hand carts (may be hired from Palexpo, contact the Exhibitor Relations Office); please do not overload these, especially when using the ramp (risk of accidents).

The following vehicles **are not allowed** in the entrance hall and the Conference Centre:

- forklift trucks (except those provided by Palexpo SA);
- electrical trolleys;
- pallet transporters with metal or rubber wheels.

4.3.3 Main entrances' outdoor esplanade (red asphalt)

This area of Palexpo is a pedestrian zone strictly forbidden to all vehicles, bicycles and machines, regardless of the number of wheels.

Wheelchairs for persons with reduced mobility are permitted.

5. CUSTOMS

Exhibits, goods for sale, stand material, brochures, promotional gifts and so on must be cleared.

We recommend carrying out customs formalities at Palexpo's Customs Office, without failing to announce yourself for formalities at the border customs office when entering Switzerland.

5.1 Palexpo's Customs Office

There is a Customs Office in the Palexpo Ibis Hotel premises:

**Douane Genève Aéroport
Bâtiment GVA-Center**

Route de l'Aéroport 31, P.O. Box
1215 Genève Aéroport 15

Tel.: + 41 (0)58 469 28 36

Fax: + 41 (0)58 484 20 55

douane.geneve_aeroport_palexpo@bazg.admin.ch

5.1.1 Customs clearing times:

- Monday to Friday: 8.00 – 11.30 am and 1.30 – 5.30 pm
- Saturday and Sunday: closed

For information on customs-related matters, contact the Central Information:

Tel.: +41 (0)58 467 15 15

infodouane@bazg.admin.ch

5.2 Surety for Swiss import duties/ATA document

5.2.1 With ATA document

The ATA document (ATA standing for Admission Temporaire – Temporary Admission) is an international customs document for temporary admission and for national transit.

The use of the ATA document is provided for goods admitted for temporary importation. But, it is not allowed for goods meant to be sold or rent for swiss stands and for consumable goods during fairs (see paragraphs concerning goods below).

Users must provide surety for prospective liability for import duties on exhibits and stand material, until the goods leave Switzerland. By far the easiest way of doing this is to use the ATA document; this speeds up customs formalities at the Swiss border, in the country of origin, and in transit countries.

Use of an ATA carnet is strongly recommended.

Users should obtain the ATA document from their Chamber of Commerce and complete it at their leisure. Please remember to list the exact weights of exhibits and stand material since, unlike most countries, Switzerland charges import duty on gross weight, not on value.

Please also bear in mind the following requirements:

- The completed ATA document must be attached to other documents sent with the goods;
- The ATA document must be presented at the Swiss Customs Office. For the Canton of Geneva, this means the following border crossing points:
 - Bardonnex (this border crossing point is on the motorway – please note that you will require a road tax disc costing CHF 40.-).
 - Thônex-Vallard (this border crossing point is on the motorway). This customs office is closed on Saturday and Sunday, vehicles will have to transit through Bardonnex.
 - Ferney-Voltaire (Limited opening hours – Tel.: +41 (0)58 481 92 80). This customs office is closed on Saturday and Sunday, vehicles will have to transit through Bardonnex.
- The ATA document has the following detachable unused sheets:
 - Two blue transit sheets for the transiting of goods from the border to Palexpo Customs Office;
 - Two white sheets for clearance at the Palexpo Customs Office;
 - Two blue transit sheets for return transport to the border;
 - Do not forget to bring enough yellow sheets for the return journey.

All goods declared at the border for transit must be registered immediately upon arrival at the Palexpo Customs Office, by submitting the ATA document.

5.2.2 Without an ATA document

Swiss customs formalities are more complicated if you do not have an ATA document. A customs declaration for temporary admission (DDAT), which guarantees the identity of the goods throughout the exhibition period, must be completed. Lists (four copies) are required containing precise details of the nature, material, net weight, gross weight and value of each item.

In principle, a DDAT can be issued only at the Palexpo Customs Office, since the necessary time and facilities are not usually available at border crossing points.

A common transit document (T1/ T2) must be obtained for the transportation of goods from the border to the Palexpo Customs Office and back.

To obtain clearance with a DDAT and a bond note, the value of the import duties must be deposited in cash, or customs security provided (e.g. by a forwarding agency domiciled in Switzerland).

All goods declared for transit at the border must be registered immediately upon arrival at the Palexpo Customs Office, by submitting the bond note.

5.2.3 Validity of ATA documents and DDATs

- Under an ATA document: validity period of the ATA document;
- Under a DDAT: 24 months maximum;
- Under an exhibition's DDAT: 6 month maximum.

5.3 Goods admitted for temporary importation

The following goods can be cleared for temporary importation into Switzerland with an ATA document or a DDAT:

- Exhibits such as machines, devices and display products, including demonstration models;
- Goods needed for the demonstration of foreign machines or devices (e.g. wool for demonstrating a knitting machine, iron rods for cutting or bending machines, and so on). Products of any kind resulting from such demonstrations must be re-exported, destroyed under customs supervision, or cleared through customs on entering Switzerland;
- Stand equipment, i.e. goods, stand fittings or objects needed to present foreign exhibits, such as partitions, showcases, shelves, furniture (e.g. tables, chairs, desks), kitchen equipment (e.g. refrigerators, coffee machines), curtains, carpets and similar, sound recordings, films, slides, and all devices and equipment needed in this respect.

Goods admitted for temporary importation may not be removed from the exhibition premises without authorisation from the Palexpo Customs Office.

5.4 Duty-free goods

The following goods can be cleared entirely of customs duty if, **in the opinion of the customs authorities**, their total value and quantity are appropriate to the size of the stand and the exhibition:

- Products temporarily imported for erecting and decorating foreign stands, such as nails, paints, lacquers, wallpaper, and so on;
- Consumable goods, such as paints, lacquers or washing powders, that are to be demonstrated themselves or are required to demonstrate foreign products;
- Printed advertising material for foreign exhibits. This material must be stored at Palexpo;
- Samples of foreign goods on exhibition, recognisable as such, of no commercial value (not corresponding to the items found on the market), supplied free of charge, and available for tasting or as gifts to stand visitors.

5.5 Goods subject to taxes

The following items, in particular, are liable for import tax under the Federal Law of 9 October 1986 on customs charges (LTaD - RS 632.10):

- Goods for sale;
- All types of gift items;
- Samples of alcoholic beverages, tobacco products, and fuels.

These taxes may consist of customs duty, VAT (value-added tax), proprietary duties, and other customs charges.

5.6 Other import restrictions

Furthermore, certain goods, particularly foodstuffs, may be subject to restrictions (licences) or import bans. The relevant information will be supplied, on a case-by-case basis, by the Palexpo Customs Office:

Tel.: +41 (0)58 469 28 36

<https://www.bazg.admin.ch/bazg/en/home.html>

5.7 Goods of animal origin

All goods of animal origin must be mentioned clearly in the customs declaration. These goods may be subject to import conditions. Goods covered by the Washington Convention need a presentation to the border veterinary service with a CITES licence issued by the country of origin as well as an import permit from the OVF (Federal Veterinary Office). Once the goods have been checked, they should be presented to the Customs Office together with the import documents.

5.7.1 Veterinary inspection

Regulations for import or re-export of animals and animal goods may be downloaded from the official Federal Veterinary Office:
www.blv.admin.ch/blv/en/home.html

Further information may be obtained from:

1) For imports from third countries (including cities EU/third country) :

Service vétérinaire de frontière

P.O. Box 1001

CH-1211 Geneva 5 Airport

Tel.: +41 (0)22 717 73 45

svf-aig@blv.admin.ch

<https://www.blv.admin.ch/blv/en/home.html>

2) For imports from the European Union (excluding cities):

Service de la consommation et des affaires vétérinaires (SCAV)

Quai Ernest-Ansermet 22

P.O. Box 76

CH - 1211 Geneva 4

Tel.: +41 (0)22 546 56 00

Fax: +41 (0)22 546 56 96

scav@etat.ge.ch

<https://www.ge.ch/organisation/service-consommation-affaires-veterinaires>

Undeclared goods, or goods without the required documents, will be impounded by the Border Veterinary Service.

5.8 Plant protection

Importation of any sort of plant must comply with the regulations in force as they appear in Notice 1 of the Federal Agriculture Office:

<https://www.blw.admin.ch/blw/en/home/nachhaltige-produktion/Pflanzengesundheit.html> and must be mentioned clearly in the customs declaration.

Goods covered by the Washington Convention need a CITES licence issued by the country of origin, which should be sent to the Customs Office with the import documents.

The Federal Plant Protection Service will carry out an inspection on the exhibition premises.

For further information, please contact:

Service phytosanitaire fédéral

Geneva Airport

Voie-des-Traz 20

P.O. Box 1089

CH-1211 Geneva 5

Tel.: +41 (0)58 464 33 88

phyto.geneve@blv.admin.ch

<https://www.blw.admin.ch/blw/en/home/nachhaltige-produktion/Pflanzengesundheit.html>

5.9 Items made of precious metals

Items made of or plated with precious metals, or imitations of any kind, may not be offered for sale unless they comply with the federal law of 20 June 1933 on the control of the trade in precious metals and items made of precious metals (LCMP - RS 941.31).

They must therefore be submitted to the Precious Metals Inspection Service:

Precious Metals Inspection Department of Geneva

Voie-des-Traz 20

P.O. Box 1025

CH-1211 Geneva 5 Airport

Tel.: +41 (0)58 480 66 82

geneve-aero-cmp.impo@bazg.admin.ch

<https://www.bazg.admin.ch/bazg/en/home/topics/precious-metal-control.html>

Enclosure:

Appendix 1.

Documentation regarding ExpoLog Geneva SA

PALEXPO'S EXCLUSIVE ON-SITE FREIGHT HANDLER

Route François-Peyrot 30 - CH-1218 Le Grand-Saconnex / Geneva
T. +41 (0)22 798 13 01 - F. +41 (0)22 798 13 87
info@expolog-geneva.ch - www.expolog-geneva.ch

Appendix 1

ExpoLog Geneva SA acts on behalf of Palexpo SA as

EXCLUSIVE ON-SITE FREIGHT HANDLER

The official partner manages and carries out all handling operations of cargo, whatever the origin, and this for any event taking place at Palexpo.

In this context, the ExpoLog team covers services such as unloading and reloading of your goods as well as the rental of equipment such as

- › forklifts
- › cranes
- › other lifting equipment for material and the related manpower
- › onsite storage

For further information,
please feel free to contact
the ExpoLog team:

- › Roberto Fumani
- › Lucas Fumani
- › Nicolas Malherbe
- › David Strippoli
- › Nicolas Strippoli
- › Valérie Martin

